

Workshop manual

BPW ePower Achse



Valid: 2023-08-17

Subject to change without notice.

Current versions and additional information can be found online at www.bpw.de.

Table of contents

◎ 1.	Exploded view	Page 4
◎ 2.	Spare parts list	Page 5
◎ 3.	Safety regulations, safety information	Page 8
	3.1 Safety regulations	Page 8
	3.2 Safety information	Page 9
◎ 4.	Lubrication and maintenance	Page 10
◎ 5.	Changing the brake linings	Page 22
	5.1 Resetting the threaded sleeve	Page 22
	5.2 Adjusting the clearance	Page 26
◎ 6.	Disassembly / assembly of the brake cylinders	Page 29
	6.1 Diaphragm cylinder disassembly	Page 29
	6.2 Diaphragm cylinder assembly	Page 29
	6.3 Spring brake cylinder disassembly	Page 31
	6.4 Spring brake cylinder assembly	Page 32
◎ 7.	Changing the brake disc.....	Page 36
◎ 8.	Disassembly / assembly of ePower Generators (GTU)	Page 46
◎ 9.	Encoder sensor replacement	Page 58

For the associated special tools and other maintenance work e.g.:

- Disassembly / assembly of the brake caliper
- Disassembly / assembly of wear sensing
- Change of the bellows with pressure plate
- Repair of the brake caliper guide
- Disassemble and assemble ECO Unit hub unit

see workshop manual BPW trailer axles with trailer disc brake ECO Disc TS2

1 Exploded view

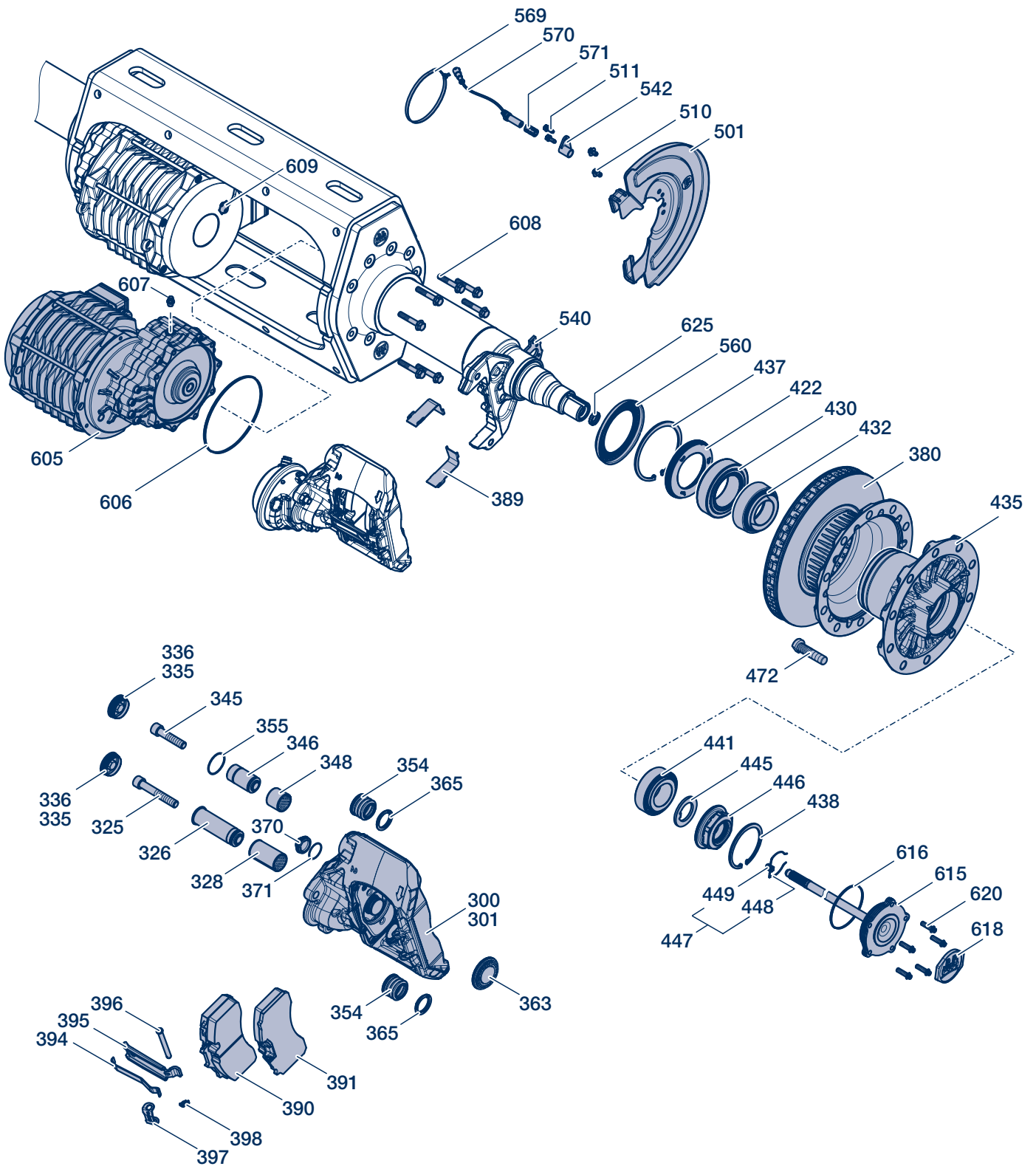

Spare parts list **2**

Item	Designation	Item number	Dimension	Qty.
300	Brake caliper	05.362.72.30.0	TS2 3709	1
301		05.362.72.31.0	TS2 3709	1
		05.362.72.32.0	TS2 4309	1
		05.362.72.33.0	TS2 4309	1
307	BPW replacement brake caliper with brake	09.362.72.30.3	TS2 3709	1
308	lining, (pre-greased), incl. guide pins, brake lining and pad retaining clip	09.362.72.31.3	TS2 3709	
	Pos. 300/301, 323, 363, 389, 390/391, 394 - 398	09.362.72.32.3	TS2 4309	1
		09.362.72.33.3	TS2 4309	
323	Guide pins repair kit inkl. Pos. 325, 326, 328, 335, 336, 345, 346, 348, 354, 335, 356, 369, 373	09.801.08.69.0	for one axle side	2
324	Cylinder head screw and sealing cap repair kit TS2 Pos. 325, 335, 345, 369, 373	09.801.08.71.1	for one axle side	2
325	Cylinder head screw	03.340.12.32.0	M 16 x 1.5 x 103 - 10.9 / SW 14	2
326	Guide pin, long (fixed bearing) incl. snap ring	05.001.00.70.0	Ø 18 / 26 / 37 x 123	2
328	Guide bush (fixed bearing)	03.112.33.13.0	Ø 37 / 41 x 73	2
335	Sealing cap, incl. item 336	05.001.00.45.0	M 49 x 1.5	4
336	O-ring	02.5679.97.40	Ø 45 x 2	4
345	Cylinder head screw	03.340.12.31.0	M 16 x 1.5 x 73 - 10.9 / SW 14	2
346	Guide pin, short (floating bearing) incl. Pos. 355	05.001.00.73.0	Ø 18 / 26 / 37 x 70	2
348	Guide bush (floating bearing)	03.112.33.16.0	Ø 37 / 41 x 34	2
354	Bellow	05.130.08.30.0	Ø 49 x 36	4
355	O-ring	02.5680.08.00	Ø 31 x 2	2
356	Ring	03.310.11.20.0	Ø 37 / 48 x 5.4	4
361	Bellow repair kit Pos. 363	09.801.08.81.0	for one axle	2
363	Bellow	05.130.08.32.0	Ø 40,7 / 75,4 Only deliverable per kit 09.801.08.81.0	2
369	Cap with O-ring incl. Pos. 370, 371	05.801.47.87.0		2
370	Cap	03.211.10.11.0	Ø 36.5 x 20.5	2
371	O-ring	02.5680.24.00	Ø 23 x 2.5	2
373	BPW ECO Disc Grease	02.1040.60.00	25 g	2
380	Brake disc	03.088.34.21.7	TS2 3709 Ø 374 x 159.5 x 45 / 10 x 22.5 / 335	2
		03.088.35.12.7	TS2 430 Ø 430 x 159.5 x 45 / 10 x 22.5 / 335	
388	Brake lining repair kit, incl. Pos. 369, 389, 390/391, 394, 396, 397, 398	09.801.08.72.0	TS2 3709 for one axle	2
		09.801.08.73.0	TS2 4309 for one axle	2

2 Spare parts list

Item	Designation	Item number	Dimension	Qty.
389	Wearing plate	03.163.04.06.0	TS2 3709 (Only deliverable per kit 09.801.08.72.0 (Pos. 388))	4
		03.163.04.05.0	TS2 4309 (Only deliverable per kit 09.801.08.73.0 (Pos. 388))	4
390	Brake lining	05.092.90.29.0	TS2 3709, BPW 8201 (Only deliverable per kit 09.801.08.72.0 (Pos. 388))	2
391	Brake lining	05.092.90.30.0	TS2 4309, BPW 8201 (Only deliverable per kit 09.801.08.73.0 (Pos. 388))	2
		05.092.90.25.0	TS2 3709, BPW 8201 (Only deliverable per kit 09.801.08.72.0 (Pos. 388))	2
		05.092.90.26.0	TS2 4309, BPW 8201 (Only deliverable per kit 09.801.08.73.0 (Pos. 388))	2
393	Pad retainer repair kit, item TS2 Pos. 394 - 398	09.801.08.70.0	for one axle	1
394	Clamping spring	03.352.00.10.0	Only deliverable per kit 09.801.08.70.0 / 09.801.08.72.0 (TS2 3709) and 09.801.08.73.0 (TS2 4309)	2
395	Brake pad retaining clip	03.001.00.64.0	151 x 42 Only deliverable per kit 09.801.08.70.0	2
396	Bolt	03.084.32.34.0	Ø 10 x 97 Only deliverable per kit 09.801.08.70.0 / 09.801.08.72.0 (TS2 3709) and 09.801.08.73.0 (TS2 4309)	2
397	Retaining clamp	03.114.43.02.0	52 x 23 x 21,5 Only deliverable per kit 09.801.08.70.0 / 09.801.08.72.0 (TS2 3709) and 09.801.08.73.0 (TS2 4309)	2
398	Lock	02.3301.31.00		2
419	Roller bearing repair kit, without axle nut and hub cap Pos. 422, 430, 432, 437, 438, 441, 445	09.801.08.41.0		2
422	Oil seal (ECO Seal)	02.5664.77.00	Ø 117 / 158 x 15	2
430	Roller bearings	02.6410.23.00	33118	2
432	Sealing ring (Grease cartridge)	03.120.47.08.0	Ø 101 / 130 x 50	2
435	eHub	03.272.43.63.0	TK 335 Dimension	2
437	Locking ring	02.5606.58.90	Ø 158 x 4	2
438	Locking ring	02.5606.22.90	Ø 122 x 4	2
441	Roller bearings	02.6410.22.00	33213	2
444	Axle nut assembly Pos. 445, 446	09.266.47.11.0	M 52 x 2 / WAF 95	2
445	Washer	03.320.65.05.0	Ø 53 / 83 x 5.8	2
446	Axle nut	05.266.47.11.0	M 52 x 2 / SW 95	2
447	Hooked spring ring cpl. with locking piece item Pos. 448, 449	05.188.04.15.0		2
448	Hooked spring ring	03.188.04.10.0	Ø 62 x 1.8	2
449	Locking piece	03.277.00.07.0		2

Item	Designation	Item number	Dimension	Qty.
472	Wheel stud (helical fit wheel stud)	03.296.33.21.1	M 22 x 1.5 / 93.6 / 58.6	20
501	Dust cover	03.010.81.79.0	TS2 4309	2
		03.010.81.80.0	TS2 3709	2
510	Locking screw	02.5071.22.00	M 10 x 15 / SW 13	4
511	Locking screw	02.5071.23.00	M 8 x 20 / SW 13	4
540	Attachment plate	03.285.34.19.0		2
542	Sensor bracket	03.189.16.55.0		2
560	Exciter ring	03.310.08.57.0	Ø 121.5 / 170 / 178 x 14.5 / Z = 90	2
569	Cable ties	02.1809.04.00	540 x 7.5	2
570	Sensor, cranked	02.3317.05.00	L = 350	2
571	Bush	02.0316.59.00		2
605	ePower Generator (GTU) (incl. Pos. 609)	05.029.80.01.0		2
606	O-ring	02.5678.78.00	Ø 209 x 3.5 ISO 3601	2
607	Air vent	02.4321.37.00	WAF 13	2
608	Locking screw	02.5071.77.10	M 12 x 70 DIN EN 1665 / SW 16	18
609	Encoder sensor with cable, incl. 2x countersunk screw M 4 (SW 2.5) and Loctite 243	05.801.47.97.0		2
615	Drive shaft	03.070.10.01.0	L = 801.5	2
		03.070.10.02.0	L = 829	2
		03.070.10.03.0	L = 851.5	2
616	O-ring	02.5678.77.00	Ø 113 x 3 ISO 3601-1	2
618	Cap BPW	03.211.17.10.0		2
620	Hexagon head screw	02.5071.78.10	M 10 x 1.25 x 35 DIN 34800, Torx E 10	10
625	Oil seal	02.5661.17.00	A 22 x 35 x 7 DIN 3760	2

3 Safety regulations, safety instructions

3.1 Safety regulations

- All work must be performed by trained mechanics at qualified service centres and authorised specialist companies who have access to all relevant tools and have acquired the know-how required for this work. Anyone who performs maintenance and repair work must be trained in automotive mechanics and already have experience in repairing trailers. Anyone who performs brake work must be trained in brake systems.
- Comply with local safety regulations.
- The relevant operation and service regulations as well as safety regulations of the vehicle manufacturer and of the manufacturers of other vehicle parts must be adhered to.
- The grinding of brake linings creates very fine-grained dust that can cause lung damage. A safety mask must therefore be worn to prevent brake dust from being inhaled.
- Use prescribed dust washing devices or vacuum cleaners for cleaning; never use compressed air or other high-pressure devices.
- Ensure adequate ventilation at the workplace.
- The vehicle must be prevented from moving during repair work. Please observe the relevant safety regulations for repair work on commercial vehicles, in particular the safety regulations for jacking up and securing the vehicle.
- During repair work, make sure that the brake is not inadvertently operated. The brake must be released.
- Do not perform repair work unless wearing protective clothing (gloves, safety boots, safety goggles, etc.) and using the recommended tools.
- Work on the brake outside of the vehicle must be carried out with the brake clamped in a device, such as a vice.
- Use only recommended tools.
- When removing the brake caliper, only touch it on the sides with your hands to avoid crushing your fingers.
- A second mechanic must provide assistance when working with heavy components (ePower Generator (GTU), (brake discs or brake disassembly/assembly).

- **The vehicle's high-voltage supply must be switched off during maintenance work.**



Warning against high voltage

- **Before starting work, the drive system is to be shut down by a specialist with high-voltage training of the level 2.**
- **Prerequisites for performing maintenance and repair work are training as a motor vehicle mechanic and high-voltage training level 1.**
- **Every motor vehicle mechanic is required to regularly update their qualifications for working on vehicles with high-voltage systems through the publication of DGUV 209-093.**

- All lines and components must be depressurized and de-energized before opening.
- Following each repair, perform a function check or take a test drive to make sure that the brakes are functioning correctly. The braking effect of new discs and linings is only optimum after a few braking actions. Avoid hard braking.
- All exchanged components must be reused or disposed of in accordance with the applicable environmental regulations, laws and directives.
- The brake caliper with the clamping unit must not be opened. The fastening screws of the cover must not be loosened.
- Depending on the use to which the vehicle is put, conduct a regular visual check of the remaining thickness of the brake pad (see page 14) and the clearance between the brake pads (see page 15).
- Tighten screws and nuts to the prescribed tightening torque.
- Only use wheels that have valves outside the wheel brace.
- If the ePower axis has to be turned to the "back position" during service / repair, make sure that small amounts of oil (droplets) can drip from the vent valve. Ensure that any dripping is caught.
- Moving the vehicle without complete wiring or connection to the ENERGe PACK is permitted. In this case, it may be moved only for transfer purposes. Real-world use is not permitted until the Axle Power System has been fully commissioned.

- The cables and connectors of the speed sensors must be secured against impacts, friction with other components and against falling down when transferring the ePower axis with generators. In addition, the connectors must be protected from environmental influences, especially moisture and dust.
- Transfer of the Axle Power System without generators connected or complete wiring is not permitted. "Open" cable ends can cause damage to the overall system.

3.2 Safety instructions

This workshop manual contains different types of safety instructions, each of which is marked by an icon and a signal word. The signal word describes the severity of the potential danger.



- | | |
|----------|--|
| Danger! | Immediate potential danger of serious or fatal injury (severe injury or death). |
| Warning! | Possible potential danger of serious or fatal injury (severe injury or death). |
| Caution! | Possible dangerous situation (minor injury or damage to property). |



- | | |
|--------------|--|
| Repair note! | Warning of damage to property or consequential damage if this information is not observed. |
|--------------|--|



- | | |
|-------|--|
| Note! | Application hints and especially useful information. |
|-------|--|



- | | |
|------------|--|
| Mandatory! | Do not use an impact wrench. Doing so would cause considerable damage! |
|------------|--|

It is essential that maintenance is carried out in accordance with the prescribed intervals in order to maintain the safe operation and road safety of the vehicle.

Rectification of any defects which are discovered or replacement of worn parts should be carried out by a BPW Service Centre or BPW Direct Service Partner, unless the vehicle owner has the required specialist personnel, the required technical facilities and workshop manuals or possesses an official certificate to perform interim inspections or special brake inspections.

When installing spare parts, it is strongly recommended that only original BPW components are used. Parts authorised by BPW for trailer axles and axle units are regularly subjected to special inspections. BPW accepts product responsibility for such parts.

BPW is unable to determine whether all third party products can be used with BPW trailer axles and axle suspensions without any safety risk; this applies even if an authorised testing organisation has accepted the product.

The warranty becomes null and void if spare parts other than original BPW parts are used for warranty work.

4 Lubrication and maintenance

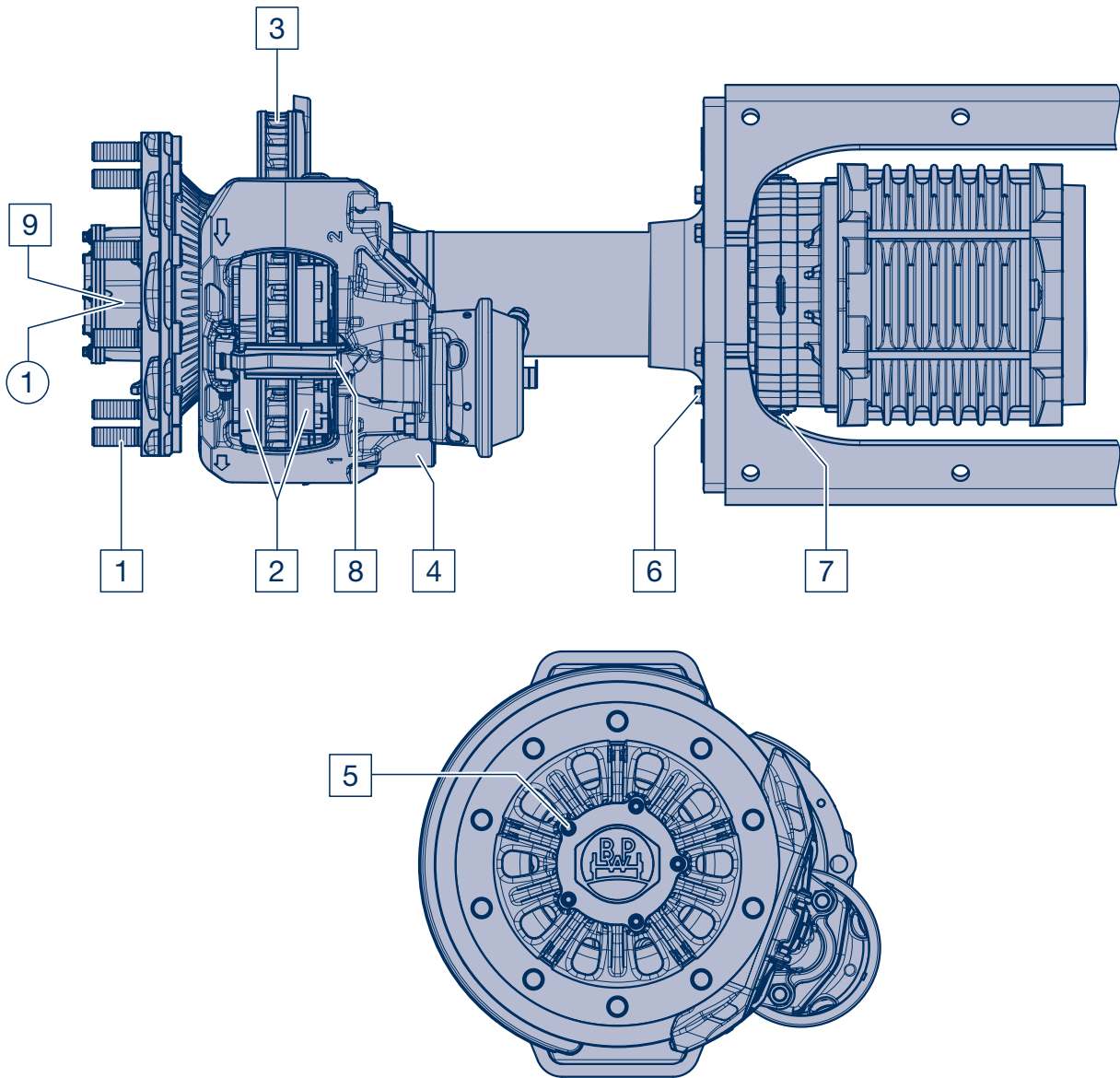

Lubrication and maintenance

Overview

For detailed description see pages 12 - 21

initially	every 12 weeks ¹⁾	every 26 weeks ¹⁾	annually and at every brake lining replacement	Annually	every 2 years	every 3 years	after 5 years, then every 3 years
-----------	------------------------------	------------------------------	--	----------	---------------	---------------	-----------------------------------

Lubrication work (lubrication with BPW special longlife grease ECO Li ^{Plus})							
① Change wheel hub bearing grease, check roller bearings and oil seal for wear. ECO Plus Unit	On-road conditions						①
	Off-road conditions					①	
	On-road conditions ³⁾			①	①		
	Off-road conditions ³⁾			①			

Maintenance							
1	Check wheel nuts for tight seat.	1 ²⁾					
2	Check brake lining thickness.		2				
-	Visual inspection, check all components for damage, wear and corrosion.			-			
3	Check the brake disc for cracking and undersize.		3 ³⁾	3			
4	Check brake caliper guide system.		4 ³⁾	4			
5	Check the fastening screws of the drive shaft for tightness.			5			
6	Check the fastening screws of the ePower generator for tightness.			6			
7	Dichtigkeit der Ölablassschraube prüfen.			7			
8	Check bellow with pressure plate.			8 ³⁾	8		
9	Check the play of the bearing of the ECO Unit; adjust if necessary.				9		

¹⁾ For heavy-duty applications, check or lubricate more frequently (e.g. off-road, heavy-duty braking work).

²⁾ After the first run under load conditions as well as after each wheel change.

³⁾ For use outside Europe:

Note: Components that have been damaged due to an improper attachment are to be replaced if necessary after a review by a BPW Service Centre.

4 Lubrication and maintenance

○ Lubrication work

① **Changing the grease of the wheel hub bearing**

- In Europe, for the first time after 5 years in on-road usage or every 3 years in off-road usage, then at least every 3 years depending on the operating conditions -
- Outside of Europe, every 2 years in on-road usage or every year in off-road usage -

Dismantling and assembling the ECO Unit and brake, see chapter 7 Changing the brake disc, work steps [1] - [11] and [31] - [47].

Disassemble and reassemble ECO Unit (with grease change or bearing replacement), see workshop manual Trailer Axles with Trailer Disc Brake ECO Disc TS2.

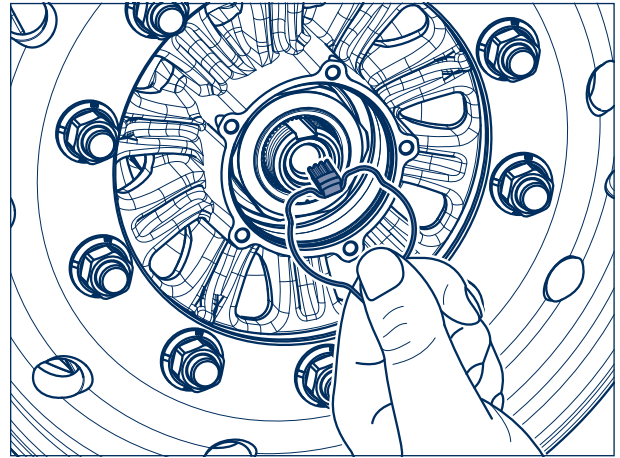

Recommendation:
 Replace the roller bearings after 5 years in on-road usage and after 3 years in off-road usage.

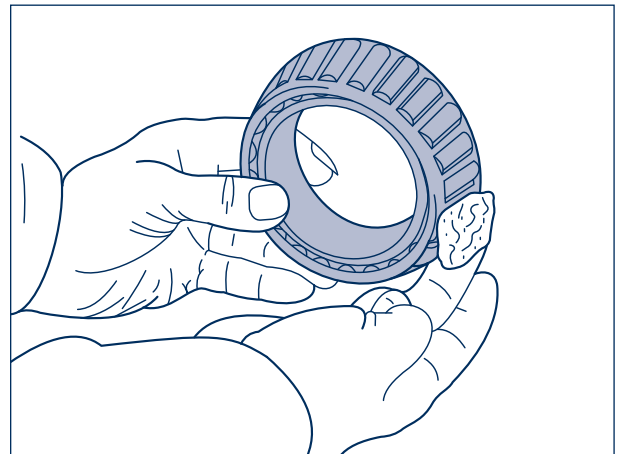

ECO Plus 3 Unit

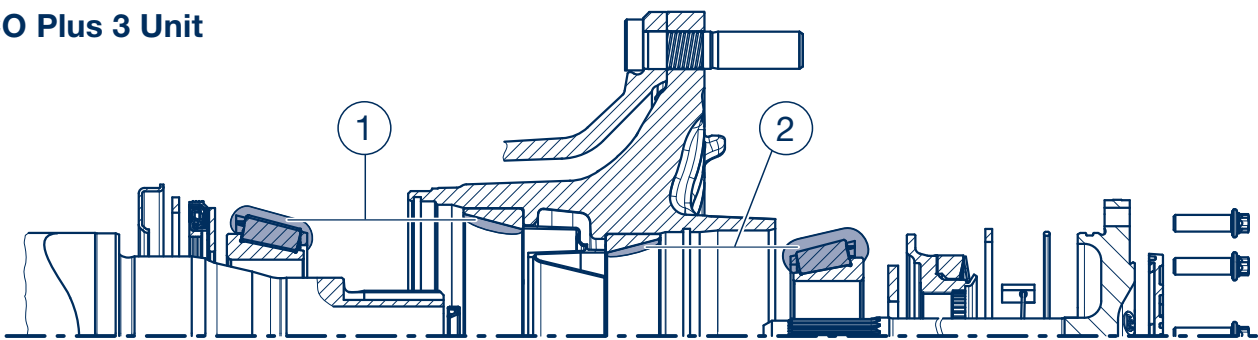

BPW special longlife grease ECO Li^{Plus}

Quantity of grease per roller bearing

	① inner	② outer
Manual lubrication	170 g	120 g
Lubrication with a grease spray	130 g	90 g

Maintenance

1 Check wheel nuts for tight seat

- The tightening torque of the wheel nuts must be checked after the first run under load as well as after each wheel change and retightened to the prescribed value if necessary -

Tighten the wheel nuts crosswise with a torque wrench to the tightening torque given in the table.

Attention: Do not exceed the specified settings!

The wheel contact surfaces should not have additional coats of paint (risk of the disc wheels becoming detached)!

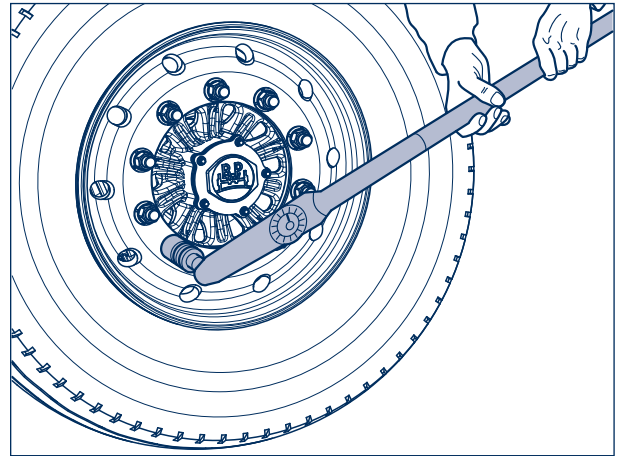

Tightening torques for wheel nuts



The prescribed tightening torques must be observed in order to ensure that the wheels are securely fastened! The wheel studs must be clean and free of damage and the nuts must be easily tightened and loosened. If necessary, lightly oil the contact surface between the wheel nut and the pressure plate. Do not oil or grease the thread of the wheel studs and wheel nuts.



The use of aggressive and acidic rim cleaners is prohibited. Such substances can severely impair the corrosion protection coating on wheel studs and wheel nuts.

Stud alignment:	Tightening torque	
M 22 x 1.5	510 Nm (485 - 535 Nm)	

Spigot alignment	Tightening torque	Wheel nut with pressure plate
M 22 x 1.5	630 Nm (600 - 660 Nm)	
M 22 x 1.5 alloy wheels	630 Nm (600 - 660 Nm)	

4 Lubrication and maintenance

2 Check brake lining thickness – quarterly –

Check the brake lining thickness regularly, e.g. when checking the tyre pressure, or after three months at the latest.



Warning!
Worn brake linings reduce the braking performance and can ultimately cause the brakes to fail completely!

Inspection can take place as follows:

The brake pad thickness can be checked where the brake caliper meets the welded anchor plate with the wheels mounted (approximate wear indicator).

Dimension x (distance between brake caliper and brake anchor):

12 mm => new condition

TS2 3709 / 4309

31 mm => max. permissible brake lining wear
19 mm

35 mm => max. permissible wear for brake lining and brake disc

The brake linings must be removed to inspect them more closely; see chapter 5.

Scorched, glazed over, or oily brake linings must be replaced immediately.

The remaining brake lining thickness must **not** be less than 2 mm (check with a caliper gauge).

Hairline cracks at the edges are OK; replacement is required if more sizable surface cracks are present.



Repair note!
Only ever replace brake linings axle by axle!

- Visual inspection – every six months –

Check all components for damage, wear and corrosion.

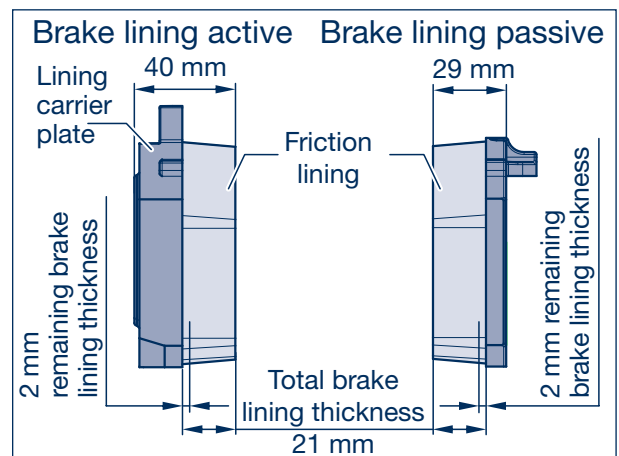
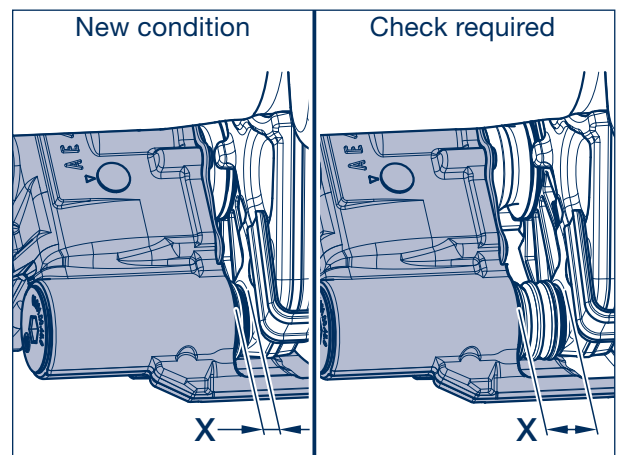
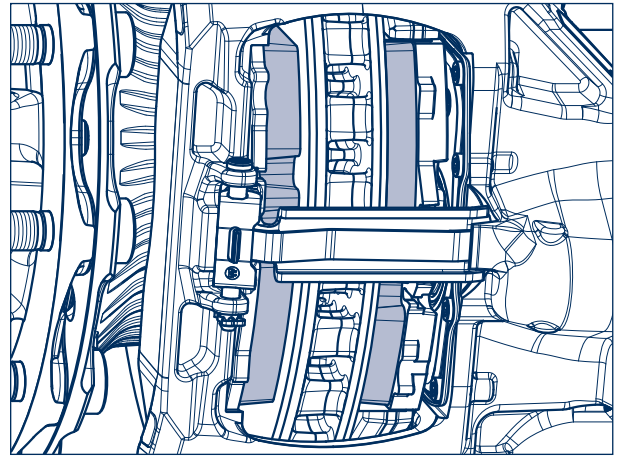

3 Brake disc

(Checking the condition of the brake disc)
 – Every six months when used within Europe and
 every three months when used outside Europe –

Sections **A - D** (fig.) show the possible conditions of the disc surface:

- A** → Network-type cracks = permissible
- B** → Radial cracks up to max. 1.5 mm width and depth = permissible
- C** → Uneven disc surface less than 1.5 mm = permissible
- D** → Continuous cracks = **not permissible**

Technical data:

Disc thickness, new = 45 mm
 Minimum permissible disc thickness = 37 mm
 Maximum wear per side = 4 mm
 (check with a caliper gauge where the brake linings make contact).

In the case of surface conditions as described for sections **A - C**, the brake disc can be used until the minimum permissible disc thickness has been reached.

Changing brake discs (see chapter 7).



Repair note!

To prevent the brake disc from being damaged, the brake linings must be replaced at the latest when the brake lining thickness has been measured at 2 mm over the carrier plate.



Repair note!

Brake discs should always be replaced on the same axle at the same time. The brake linings should also be replaced when new brake discs are installed.



Warning! If these instructions are not followed, there is a danger of the brake disc being damaged, and a reduction in or complete loss of the braking effect.

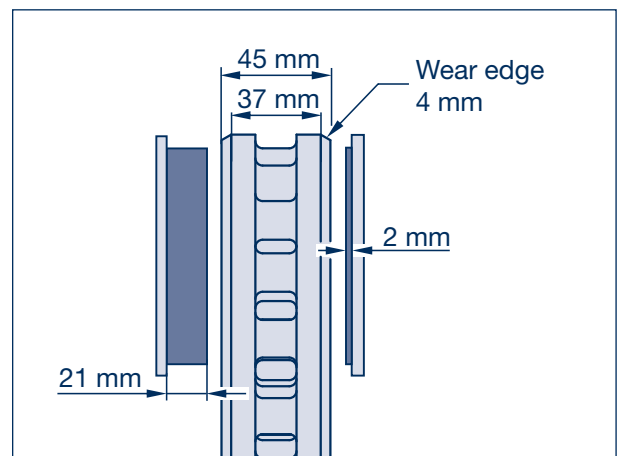
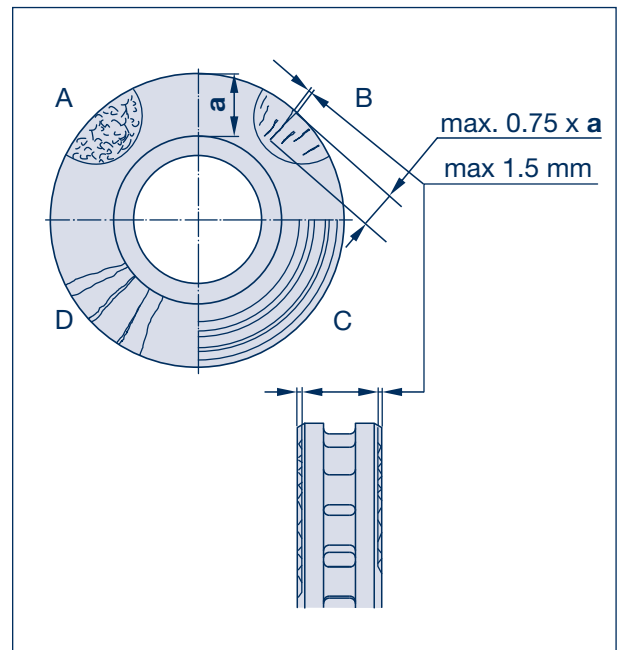

4 Lubrication and maintenance

4 Check the brake caliper guide system

(check clearance and adjustment)

- Every six months when used within Europe, every three months when used outside Europe – (e.g. within the scope of the statutory checks)

**Secure the vehicle from rolling away.
Release the service and parking brake.**

The brake cylinder and fasteners for the brake pads can remain fitted. Push the sliding caliper in the axle direction.

Strong pressure in the direction of the axle must cause the caliper to move approximately 0.7 to 1.6 mm (play).

If the clearance is not within the tolerance, the brake caliper guide and the adjustment should be checked (see page 17).

Close examination of the clearance with the wheels mounted:

Use a dial gauge to determine the play. For this purpose, attach a dial gauge holder to the axle beam and position the probe on the outside of the fixed bearing sealing cap (335) or on the brake cylinder.

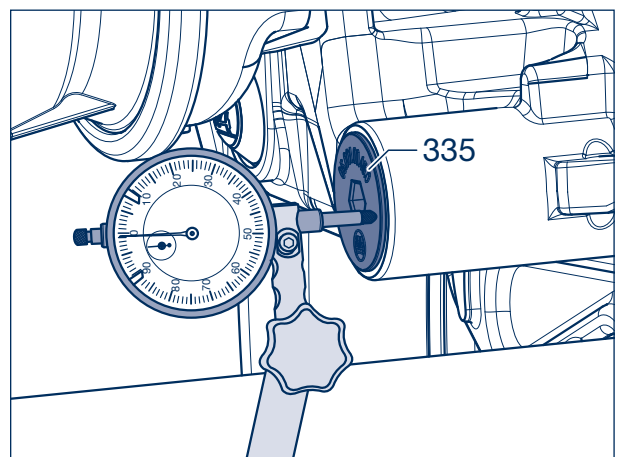
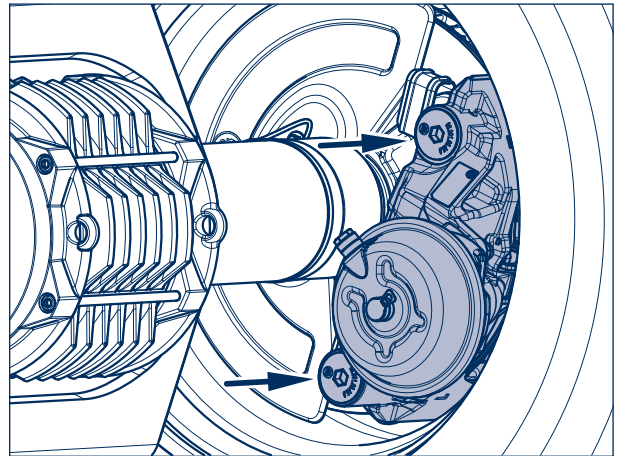

Close examination of the clearance with the wheels removed:

Use a feeler gauge to check the clearance.

Forcefully push the sliding caliper in the direction of the axle centre. Insert the feeler gauge between the bellow with pressure plate (363) and the brake lining back plate (390).

If the clearance is not within the tolerance, the adjustment and the brake caliper guide should be checked.

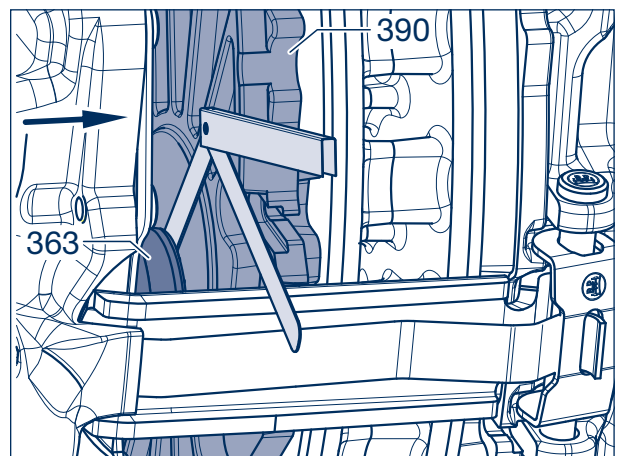

Only with n.i.O. clearance:

Adjusting the clearance and checking the adjustment

1. Remove the sealing cap (370).
2. Turn the resetter with a spanner (SW 13) 90° **counterclockwise**

Max. reset moment: 15 Nm

3. Actuate the brake 5 to 10 times with approx. 2 bar.
4. When the sliding caliper is forcefully pushed in the direction of the axle, it must now be possible to move the sliding caliper by the clearance of 0.7 - 1.6 mm.

If the clearance is correctly set, the adjustment is OK.

Use a new sealing cap and press it into the brake caliper while compressed (vented) (observe the installation instructions on pages 26 - 28, section 5.2).



Warning!

Failure to install the sealing cap correctly may result in moisture getting into the brake and corroding the adjustment. This can reduce the braking effect or even cause it to fail completely.

Checking the brake caliper guide:

The brake caliper guide must be checked if the clearance has not been adjusted correctly.

Disassemble the brake linings, see chapter 5. It must be possible to move the brake caliper slightly from end stop to end stop.

The guide bushes (328, 348) are sealed by the bellows (354) and the sealing caps (335).

Inspect the bellows and sealing caps for cracks, damage, and proper seating and replace them if necessary. **Screw plugs that have been removed must be replaced, not re-used.**

Repair of the brake caliper guide, see workshop manual Trailer Axles with Trailer Disc Brake ECO Disc TS2.

Check the brake caliper bearing play:

The bearing clearance of the brake caliper can be determined with a dial gauge. Attach the dial gauge holder to the axle beam and position the gauge on the brake caliper housing on the brake cylinder holder.

Press the brake caliper on the brake cylinder downwards vertically to its installation position and set the dial gauge to "zero".

Press the brake caliper upwards and determine the play of the bearing on the dial gauge.

If the play of the bearing of a brake caliper exceeds 1.0 mm, the brake caliper bearing must be replaced.

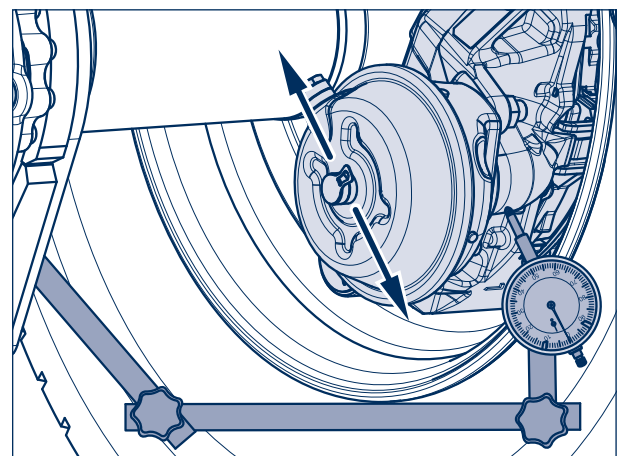
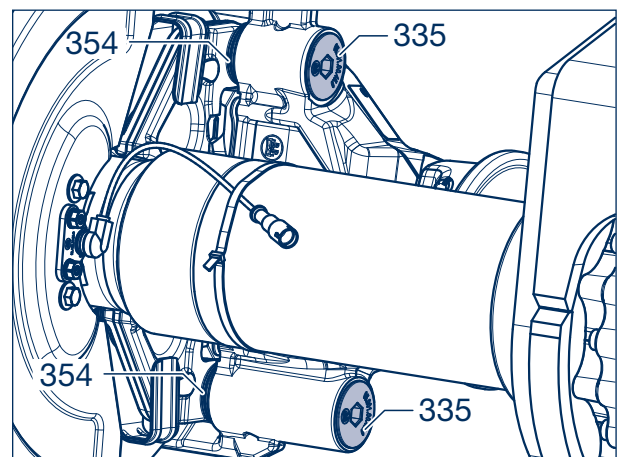
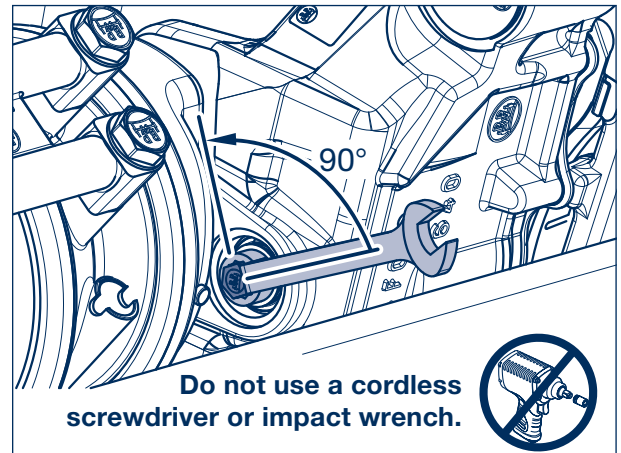

4 Lubrication and maintenance

- 5 Check the fastening screws of the drive shaft for tightness**
– semiannually –

Check the hexagon head screws (M 10 x 35) for tightness using a torque wrench and an E10 socket.

Tightening torque: **75 Nm** (65 - 82 Nm)

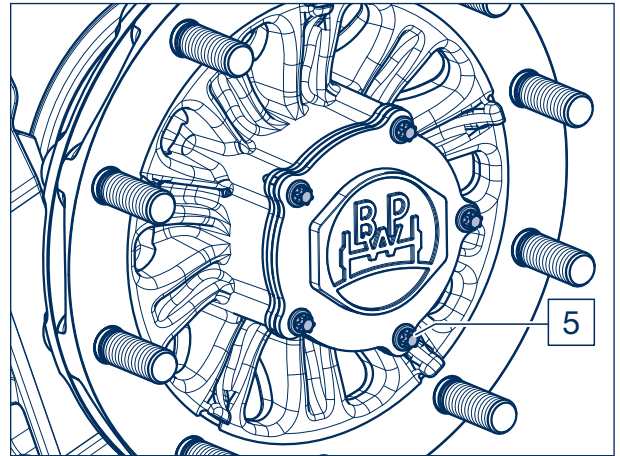

- 6 Check the fastening screws of the ePower generator for tightness**
– every six months –

Determine the existing tightening torque of the locking screws (M 12 x 70, SW 16).

If there is a control torque of **95 Nm**, the fastening is sufficient. Please do not determine a further torque! The screw locking adhesive would break loose.



Repair note!

If the screw bonding is loosened during the tight fit test and the screw is turned further, the screw must be dismantled.

Clean the thread in the axle beam and ePower generator.

Fit new, prescribed locking screw and tighten to 103 Nm (94 - 112 Nm).

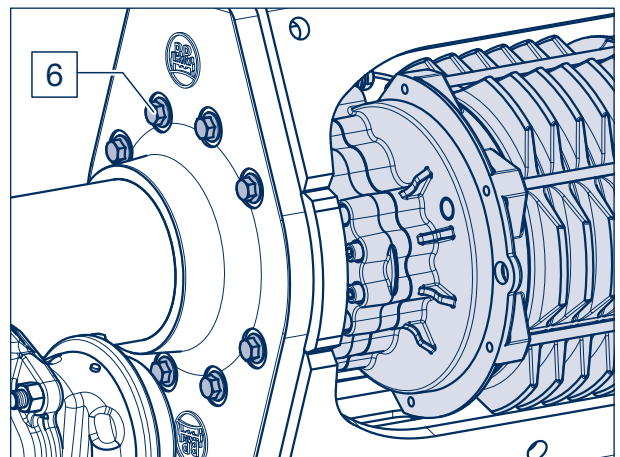

- 7 Check the tightness of the oil drain plug**
– every six months –

Check the tightness of the oil drain plug on the ePower generator, tighten it slightly if necessary.

Tightening torque: **11 Nm**

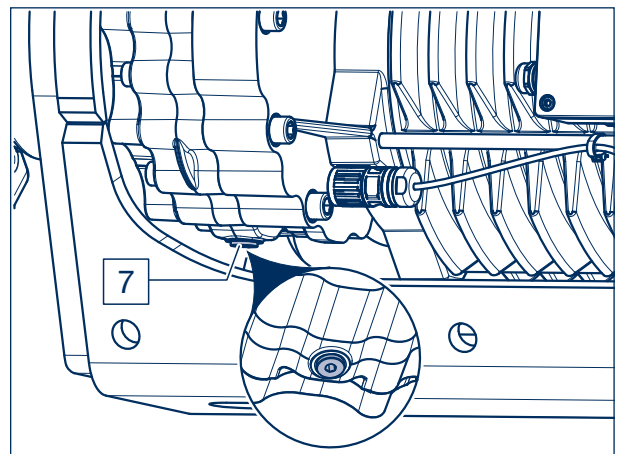

- 8 Check the bellow with pressure plate**
 – at every brake lining replacement and at the latest annually,
 every six months when used outside Europe –

Secure the vehicle from rolling away.
 Release the service and parking brake.

Disassembling brake linings (390, 391), see chapter 5. The service brake and spring brake must be in the released condition.

Pull the pressure plate with heat protection cover and bellow (363) out of the dust cover slightly.

Check the complete unit for proper seating and damage; replace it if necessary.

Check the dust cover (arrow) for deformation. If a deformation is detected, the brake caliper must be replaced!

If a thermal overloading of the brake has been detected, the bellow with pressure plate (363) must be replaced.

Before the new bellow with pressure plate is installed, the adjusting unit must be checked for corrosion and ease of movement .

After the check or replacement, the bellow must be folded correctly and returned to its initial position. The pressure plate rests against the threaded sleeve

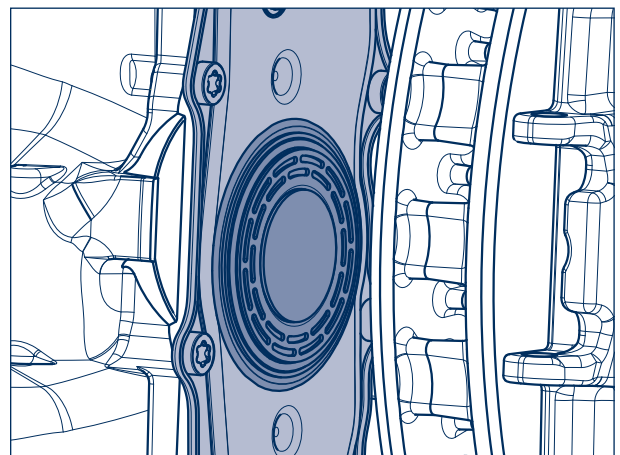
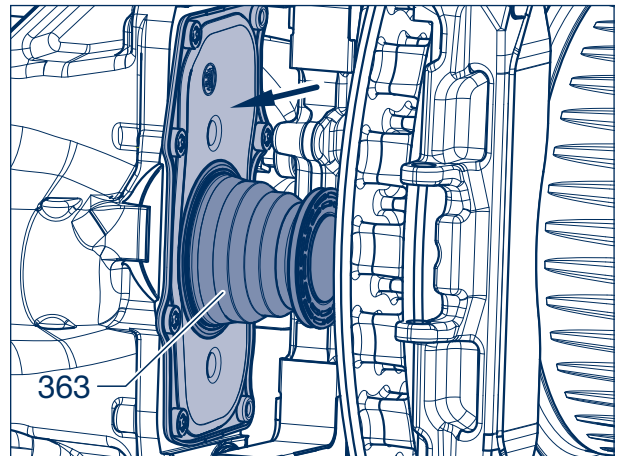

Repair note!

The bellow with pressure plate must be replaced each time that the brake disc is changed.

Changing the bellows with pressure plate, see workshop manual Trailer Axles with Trailer Disc Brake ECO Disc TS2.



Repair note!

Penetrating dirt and damp cause corrosion and affect the operation of the clamping mechanism and adjustment.

4 Lubrication and maintenance

- 9 **Check the play of the bearing of the wheel hub**
– at every brake lining replacement, at the latest annually –

**Secure the vehicle from rolling away.
Release the service and parking brake.**

In order to check the play of the bearing of the wheel hub, lift the axle until the tyres are off the ground. Release the brake. Apply a lever between the tyre and the ground and check the clearance.

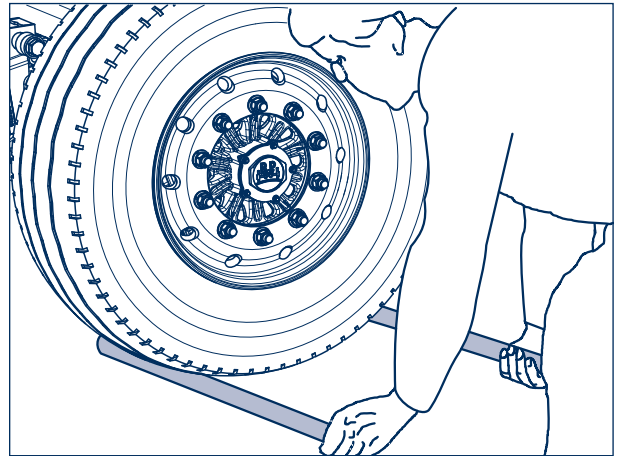

Adjust the play of the bearing:

1. Unscrew the hexagon head screws from the drive shaft.
2. Pull the drive shaft out of the stub axle.

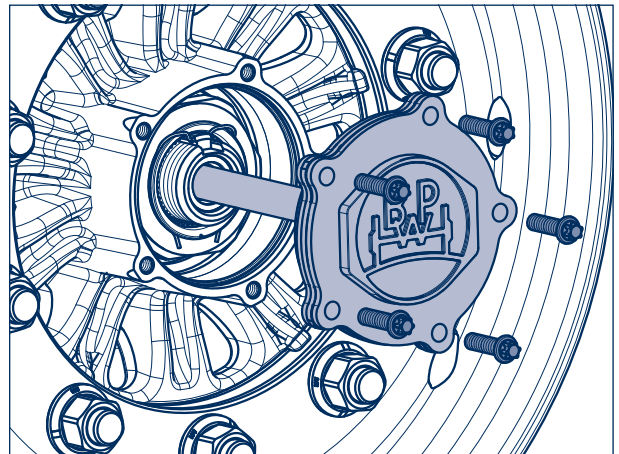

3. Remove the hooked spring ring with a wedge from the axle nut.

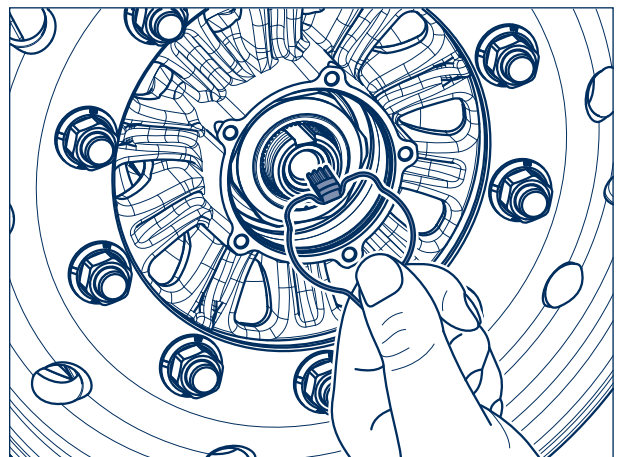

4. Tighten the axle nut while continuously turning the ECO Unit with a socket wrench for axle nuts (BPW part number: 05.364.26.05.0). The ECO Unit must rotate several times before the tothing slips over the axle nut.



Attention!
Do not use an impact wrench.

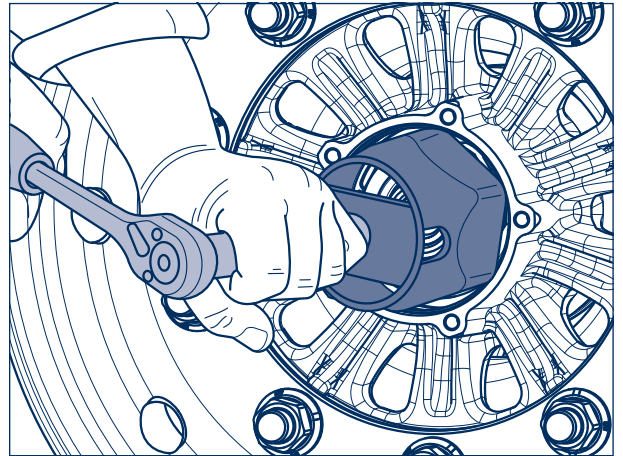

5. Fit the retaining key in the groove between the axle stub and the nut (do not reset the axle nut).
6. Hook the hooked spring ring behind the formed edge of the axle nut.
7. Lever the shaft seal ring (arrow) out of the steering knuckle.
8. Press the new oil seal straight into the steering knuckle (with the closed side facing outwards) until it rests against the contact surface in the steering knuckle.



Repair note!
When pressing in, take care not to damage the seal. Do not use sharp-edged objects (e.g. screwdrivers).

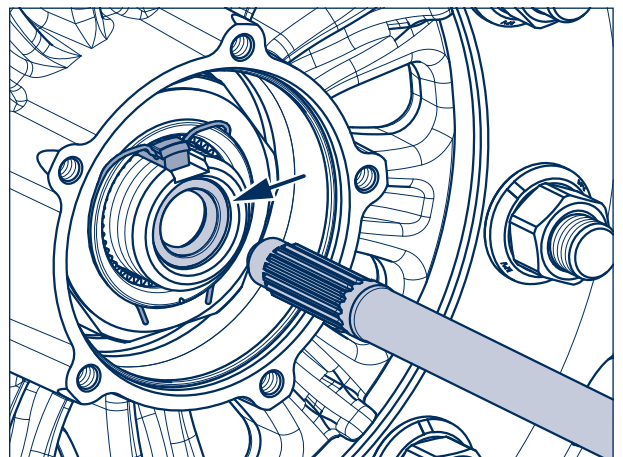

9. Coat the oil seal with BPW special longlife grease ECO-Li^{Plus}.
10. Coat the teeth of the drive shaft with Renolit PW paste and insert it into the steering knuckle or the ePower generator.



Repair note!
Carefully insert the shaft splines so that the shaft seal is not damaged.

11. Mount the new O-ring on the drive shaft (arrow) and coat all around with BPW special longlife grease ECO-Li^{Plus}.
12. Mount the hexagon head screws and tighten them crosswise.

Tightening torque: **75 Nm** (65 - 82 Nm)

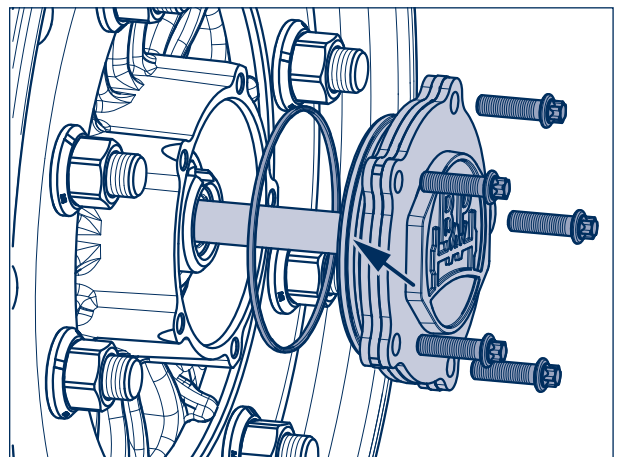

5 Changing the brake linings



Repair note!

Only replace brake linings on the same axle at the same time!
Before the new brake pads are fitted, the brake must be released completely.

- [1] Prevent the vehicle from rolling away.
- [2] Release the service and parking brake and remove the wheels.
- [3] Remove the sealing cap (370) with the O-ring (371) of the resetting device using a screwdriver.

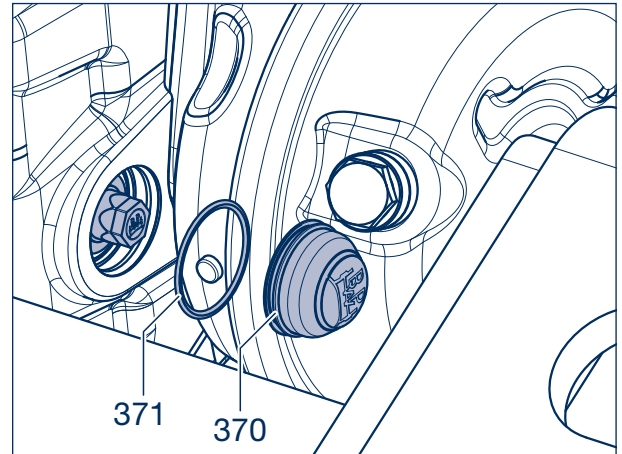

Picture 1

5.1 Resetting the threaded sleeve

- [4] Using a spanner (SW 13), turn the resetter counter-clockwise until the pressure plate with bellow has been completely reset.
(If nec., manually turn back the pressure plate with bellow to the compressed condition.)

Max. reset moment: 15 Nm



Repair note!

If the max. reset torque is exceeded, the adjustment can be irreparably damaged.



Attention!

Do not use a cordless screwdriver or impact wrench. Using these tools would cause considerable damage!

- [5] If present, remove the wear compensation (702), see workshop manual Trailer Axles with Trailer Disc Brake ECO Disc TS2.
- [6] Pull the spring split pin (398) out of the bolt (396) with a spring plier.

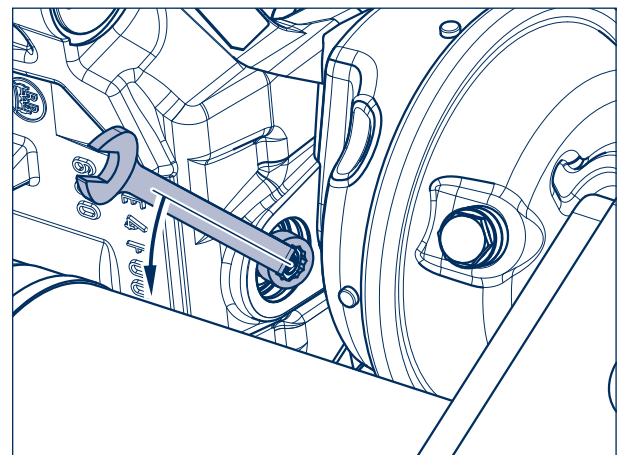
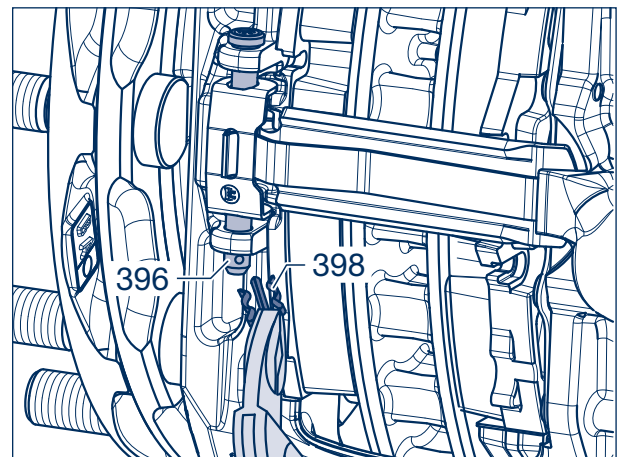
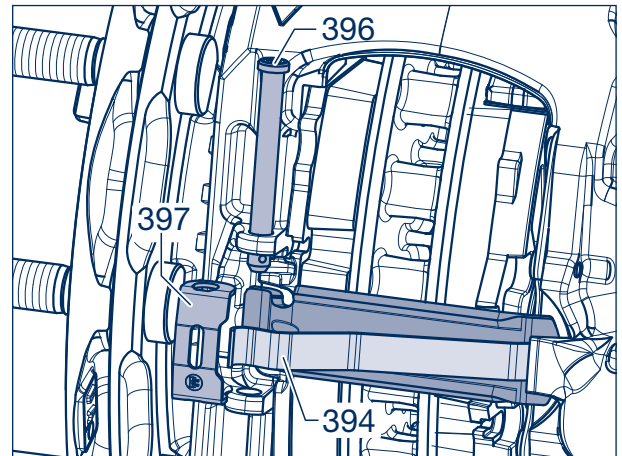

Figure 2



Picture 3

- [7] Depress the clamping spring (394) and remove the bolt (396) with holding clamp (397).
- [8] If present, remove the brake lining shaft cover (530), see workshop manual Trailer Axles with Trailer Disc Brake ECO Disc TS2.



Picture 4



Caution!
Apply counter pressure to the brake linings (390, 391) if necessary so that they do not fall out of the lining groove when the pad retainer is removed.

- [9] Remove the pad retainer (395) with clamping spring (394).

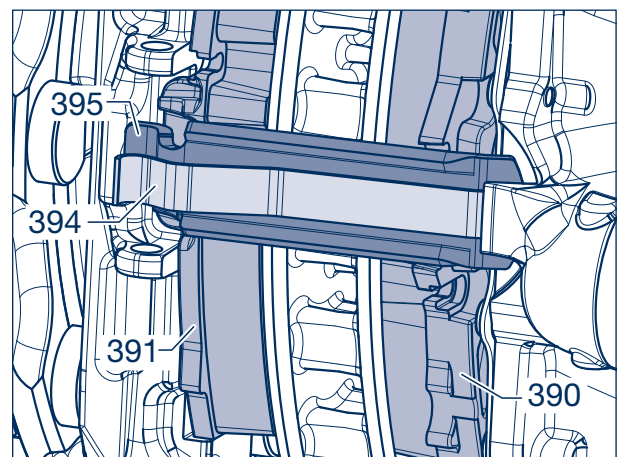

Figure 5

- [10] Remove the brake linings (390, 391).
- [11] After the brake linings have been removed, check the condition of the brake and the brake disc; see chapter 4, pages 17 to 19.
- [12] If no defects are found, you can continue with the replacement of the brake linings (390, 391).

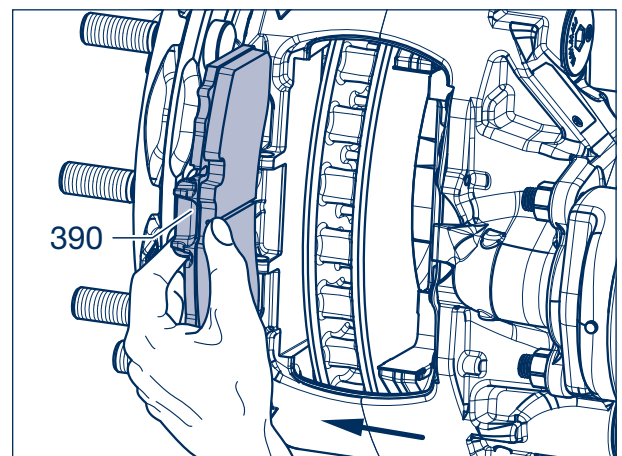

Figure 6

5 Changing the brake linings

- [13] Lever both wearing plates (389) off of the brake anchor. Clean the lining groove and the seats of the wearing plates on the brake anchor and remove corrosion.
- [14] Mount new wearing plates (389), greased on the rear side with BPW special longlife grease ECO-Li^{Plus}, on the brake anchor. The lateral mounting brackets (arrow) fix the plates on the brake anchor.



Repair note!
The brake disc must remain free of grease.



Note:
Only brake linings approved by BPW may be used. Our warranty will become invalid if this instruction is not observed!



Repair note!
If the brake disc is worn, the inner and outer radius (arrow) of the new linings must be chamfered (4 x 45°).



Repair note!
Before the brake linings are installed, it must be ensured that the bellow with pressure plate (363) rests correctly folded against the dust cover (see figure on page 29).

- [15] Move the brake caliper towards the inside of the vehicle and insert the inner, active brake lining (390).



Note:
Brake linings are supplied with different back plates.

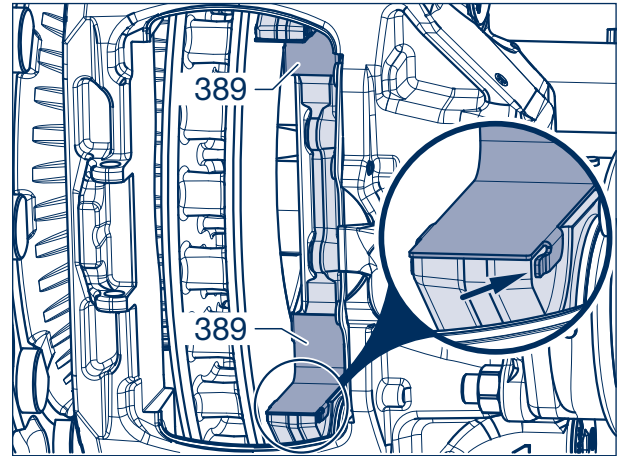

Figure 7

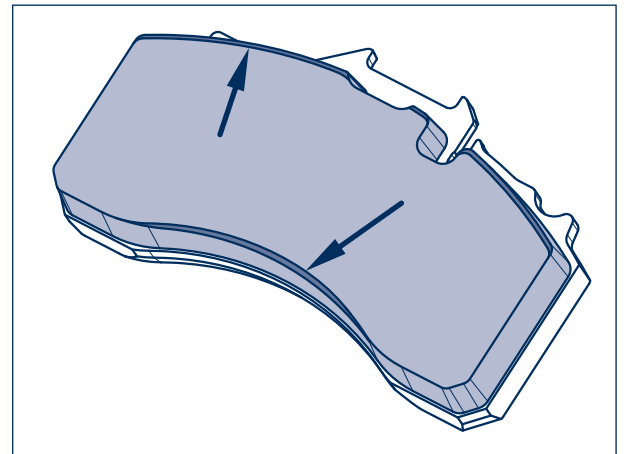
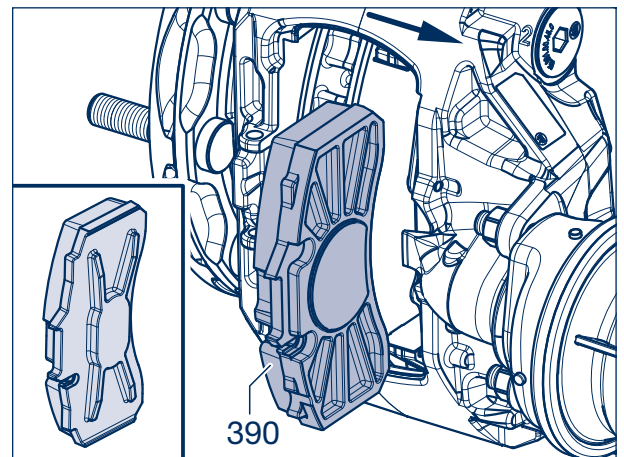

Figure 8



Picture 9

- [16] Slide the brake caliper towards the outside of the vehicle and insert the outer, passive brake lining (391).

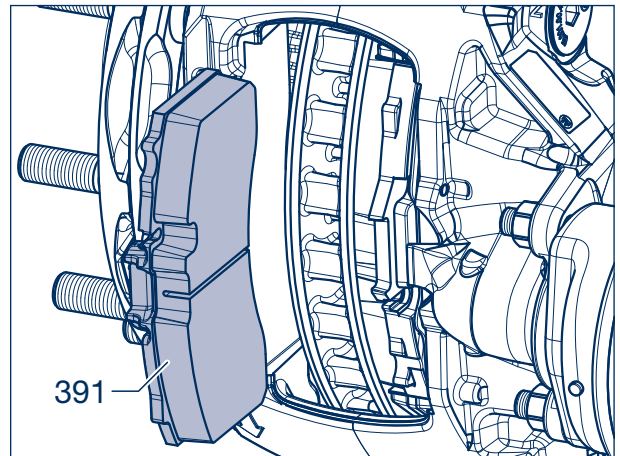
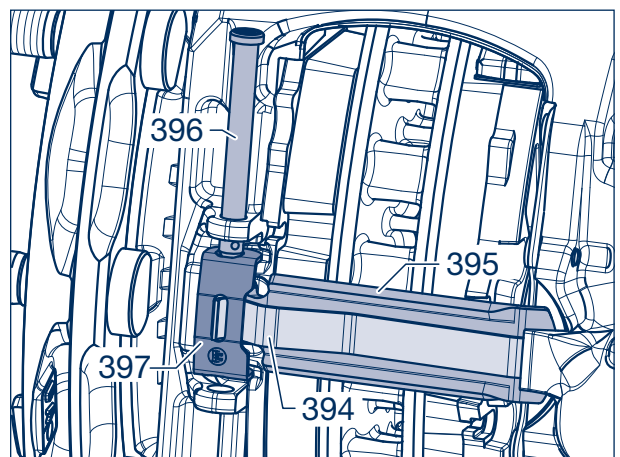

Figure 10

- [17] Guide the pad retainer (395) with clamping spring (394) into the saddle opening.
- [18] Place the holding clamp (397) onto the clamping spring and press it down together with the pad retainer until the bolt (396) can be inserted into the bore hole.
- [19] Install brake lining shaft cover (530), if removed (see workshop manual Trailer Axles with Trailer Disc Brake ECO Disc TS2).



Picture 11

- [20] Insert the bolt (396) from above, and secure it with the spring split pin (398).
- [21] Following this, ensure that the wheel or hub can turn slightly when the brake is released.

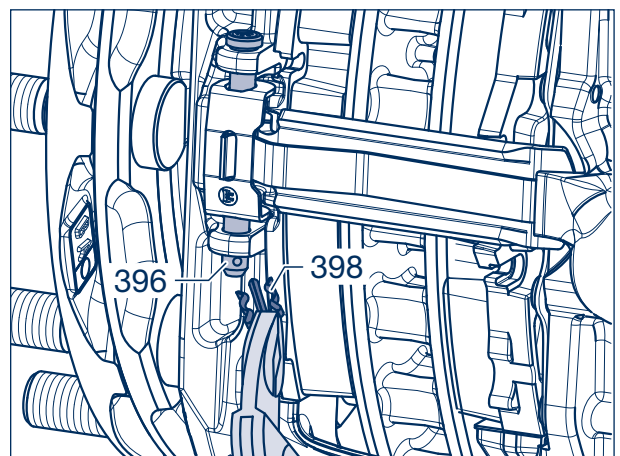

Picture 12

5 Changing the brake linings

5.2 Setting the clearance

- [22] Using a spanner (SW 13), turn the resetter counter-clockwise
- [23] Advance the brake until the brake linings rest against the brake disc free of play.

Max. torque: 15 Nm



Attention!
Do not use a cordless screwdriver or impact wrench. Using these tools would cause considerable damage!

- [24] Next, turn back the adjuster by 90°.

- [25] Apply BPW ECO Disc Grease to the entire face of the sealing bush.

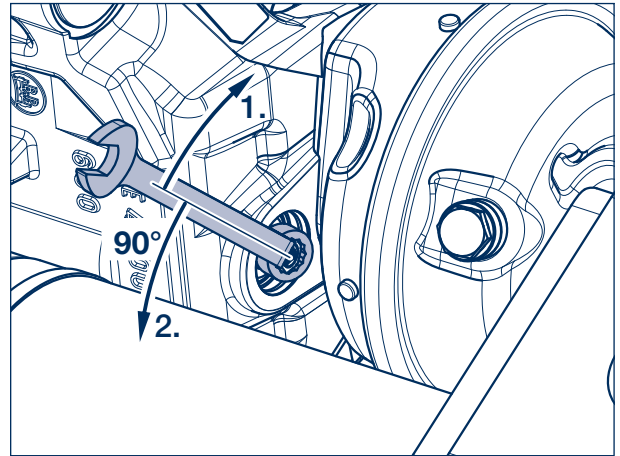

Picture 13

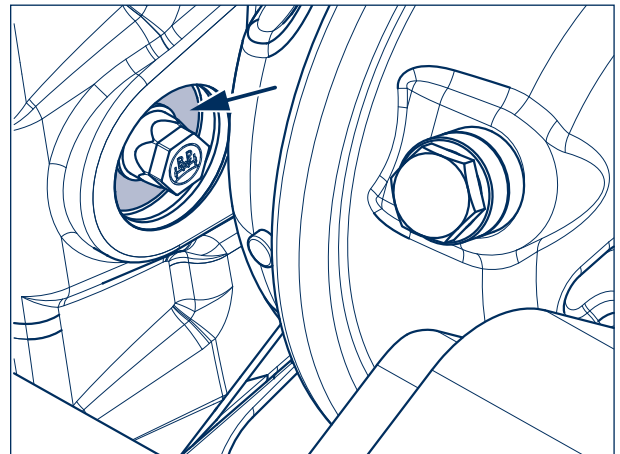

Picture 14

Mounting new cap



Attention!
It is mandatory to use one of the new sealing caps for assembly.

- [26] Insert the O-ring (without grease) into the groove of the **new blue cap**, if not pre-assembled.

When using a new black cap, the O-ring is omitted.

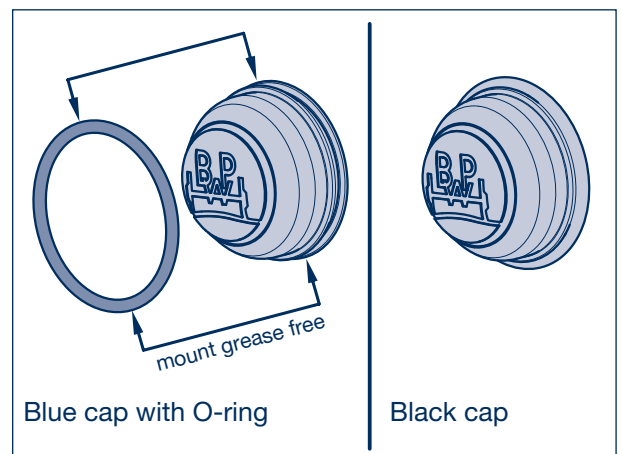

Picture 15

- [27] Coat the outside of the O-ring or black cap with BPW ECO Disc Grease.

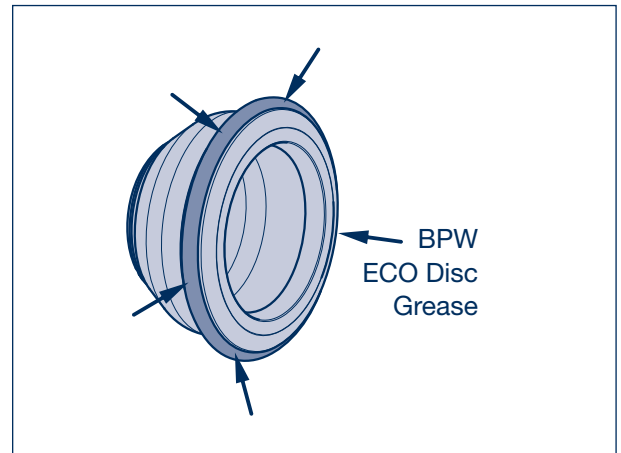

Picture 16

- [28] Position the sealing cap at an angle in the bore groove

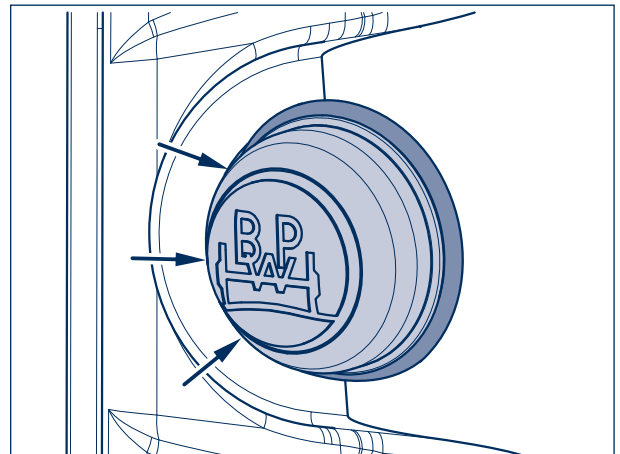

Picture 17

- [29] Insert the sealing cap with sealing lips and O-ring into the cylindrical part of the bore and then press it in until the sealing lips with O-ring engage in the bore groove.

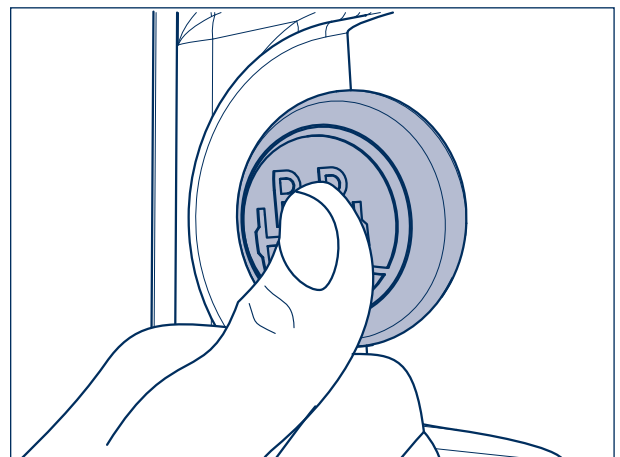

Picture 18

5 Changing the brake linings

- [30] The correct fit is established when the cap is centered in the bore and the O-ring is no longer visible.



Warning!

Failure to install the sealing cap correctly may result in moisture getting into the brake and corroding the adjustment. This can reduce the braking effect or even cause it to fail completely.

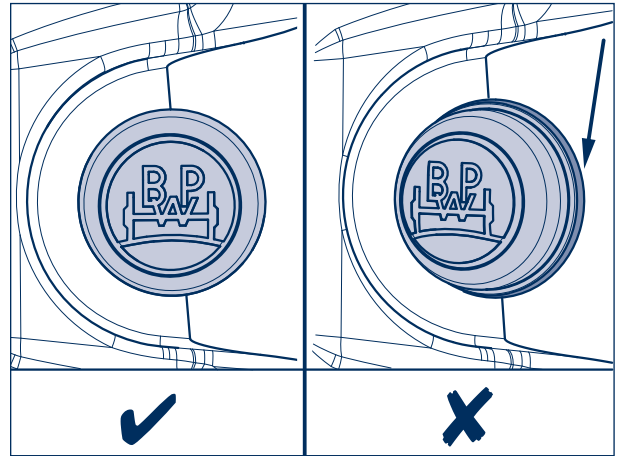

Picture 19

- [31] Attach the wheels.



Repair note!

Only use wheels that have a valve outside the wheel brace.

- [32] Screw on the wheel nuts.

- [33] Lower the axle and tighten the wheel nuts to the required tightening torque.



Warning!

The tightening torque of the wheel nuts must be checked after the first high load journey, if appropriate, retightened to the prescribed value.



Warning!

New discs and linings only have an optimal braking effect after a few braking operations. For this reason, run in new brake linings while avoiding lengthy and unnecessarily sharp brake operations.

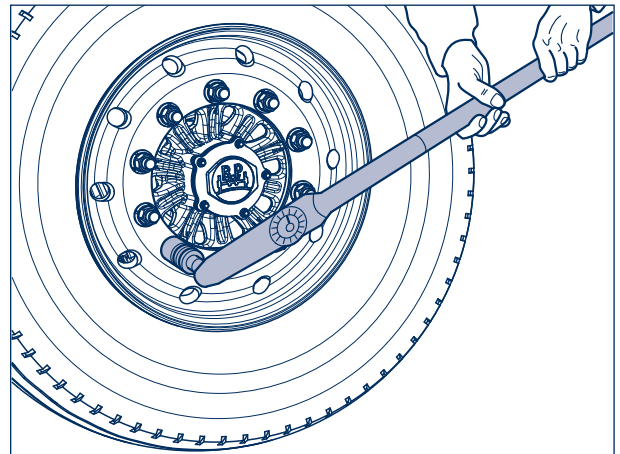

Picture 20

Removing / fitting the brake cylinders

6

6.1 Removing the diaphragm cylinder

- [1] Ensure that the brake cylinder (410) is depressurised
- [2] Unscrew air connection from brake cylinder (410) .
- [3] Loosen both attachment nuts M 16 x 1.5 - SW 24 on the brake housing.
- [4] Remove the brake cylinder (410).

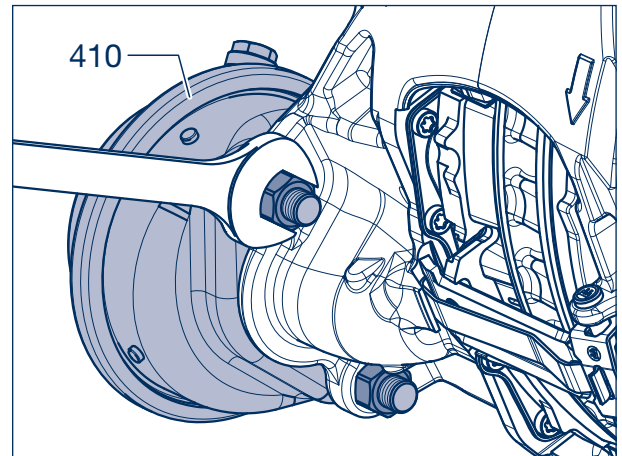

Picture 1

6.2 Assembling the diaphragm cylinder



Note!

Clean housing and brake cylinder unit surfaces before fitting. The seal (1) and push rod chamber (2) of the brake cylinder (410) must be free of dirt and moisture.

If the brake calipers are leaking, check the brake cylinders for damage. Damaged brake cylinders must be replaced.



Repair note!

Use only brake cylinders suitable for disc brakes (with "inner sealing"). (See BPW-TE 2342.0)

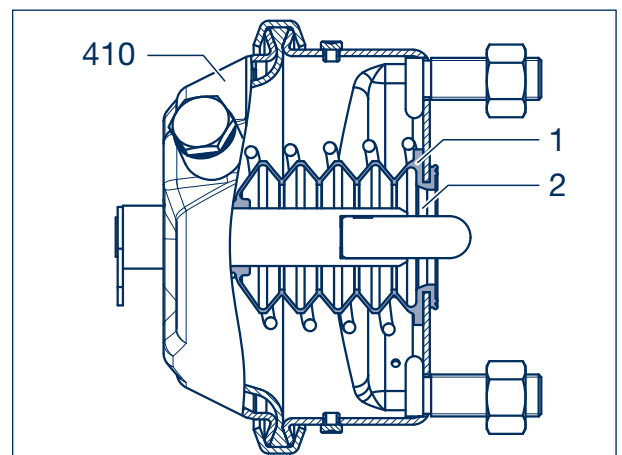

Picture 2

- [5] Before fitting the new brake cylinder (410), grease the spherical cap in the lever (arrow) with **BPW ECO Disc Grease Plus**.



Repair note!

Do not use grease containing molybdenum disulphide!

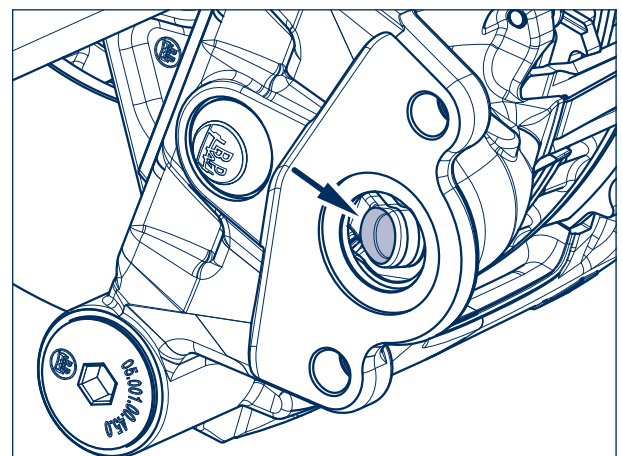

Picture 3

6 Disassembling / assembling the brake cylinders



Note!

When new brake calipers are used, the plug must be removed! Pierce the sealing plug in the centre with a thin screwdriver and pry the cap out of the brake caliper.

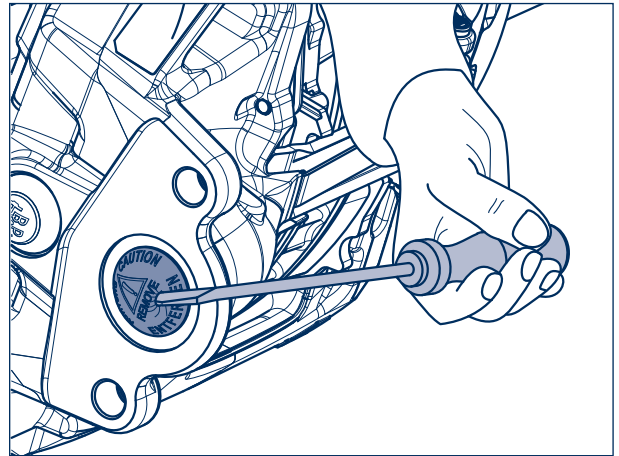

Picture 4



Caution!

Only pressurise the brake cylinder (410) when it is mounted on the brake!

- [6] Remove the plug (figure. 4/arrow) for venting from the downwards-pointing bore hole in the new brake cylinder (410).
- [7] All other vent holes must remain sealed!
- [8] Position the brake cylinder (410) and install it using new attachment nuts.
Anziehdrehmoment:
M 16 x 1.5 - SW 24 $M = 180 \text{ Nm}$ (180 - 210 Nm)
- [9] Connect the brake line (air connection) and check the sealing. The brake lines must be routed such that they do not twist or can rub against other components.

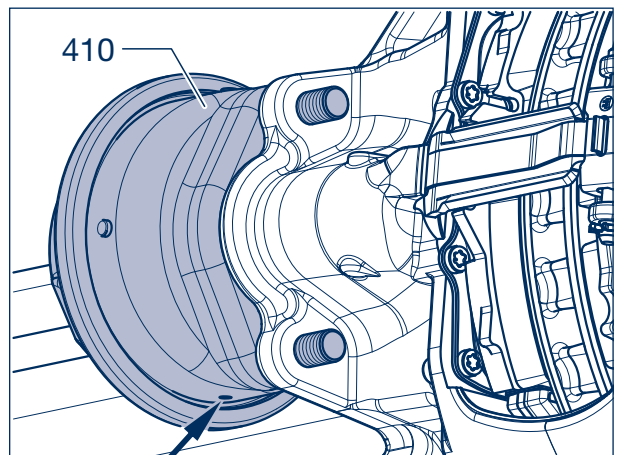

Picture 5



Repair note!

When connecting the compressed air lines to the brake cylinder, make sure the movement of the brake caliper is not obstructed by any adjacent components.



Repair note!

The air lines must be laid in such a way that no damage can be caused by the axle beam!



Repair note!

Check the functioning and effectiveness of the brake system!

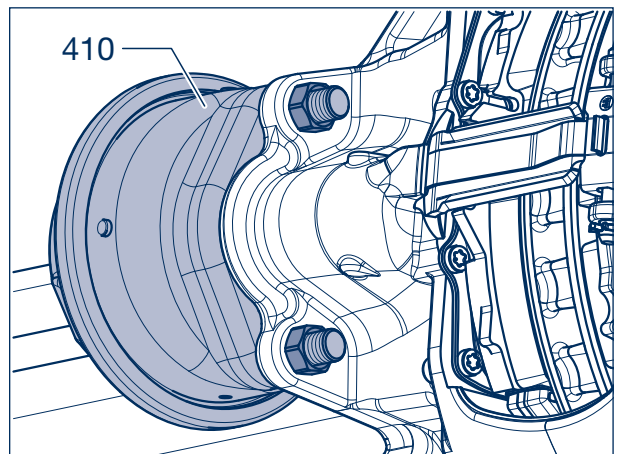

Figure 6

6.3 Disassembling the spring brake cylinders



Warning!
Before loosening the spring brake cylinders, secure the vehicle against rolling away.

- [10] Release the parking brake (hand brake valve).
- [11] Remove the lock (1) from the bore hole.

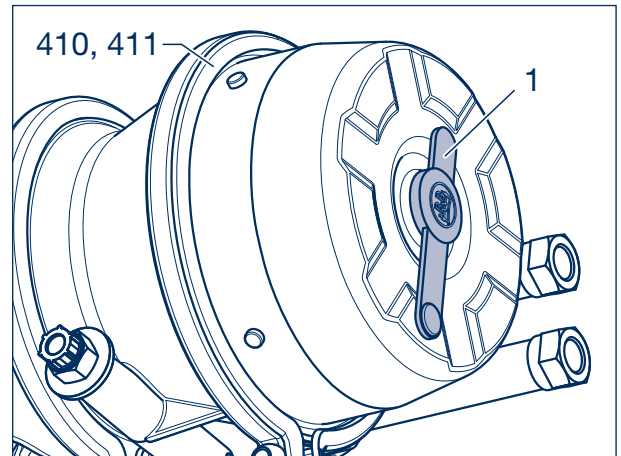

Figure 7

- [12] Remove the protective cap with thread (2), unscrew the nut (3) from the spindle (4) and remove it with the washer (5).

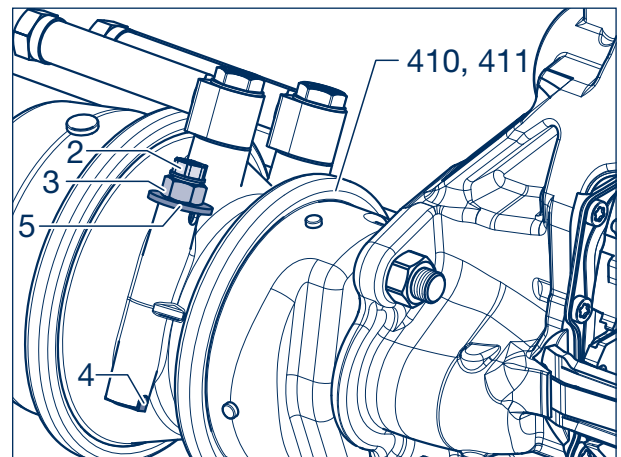

Figure 8

- [13] Insert the threaded spindle (4) into the brake cylinder (410, 411) and turn it 90° to engage.
- [14] Screw on the nut (3) and a washer (5). Tightening the nut causes the brake cylinder to be mechanically released.

In other versions, unscrew and remove the spring brake bolt (mechanical release device / arrow) by turning it counterclockwise.



Warning!
DANGER OF INJURY!
Do not use an impact wrench.
Brake cylinders must not be opened.

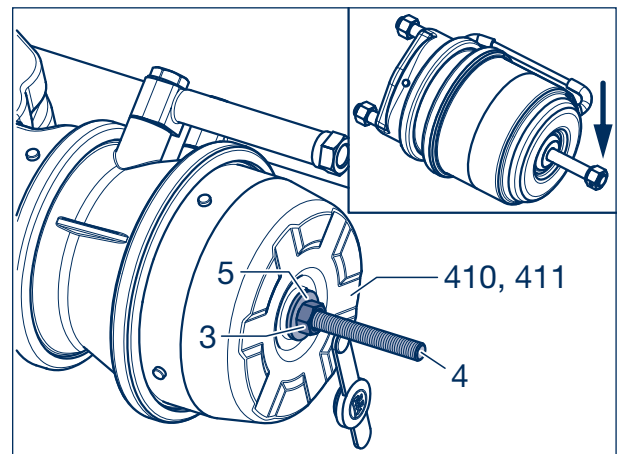

Picture 9

6 Disassembling / assembling the brake cylinders

- [15] Mark air connections for proper installation and unscrew them from the brake cylinder (410, 411).
- [16] Loosen both attachment nuts M 16 x 1.5 - SW 24 on the brake housing.
- [17] Remove the brake cylinder (410, 411).

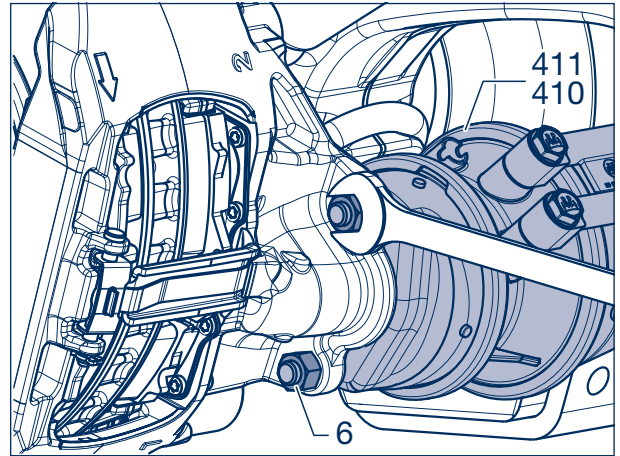

Figure 10

6.4 Assembling the spring brake cylinder



Caution!
Only vent the spring brake cylinder at connection 1.1. (Service brake) when it is mounted on the brake!



Note!
When new brake calipers are used, the plug must be removed! Pierce the sealing plug in the centre with a thin screwdriver and pry the cap out of the brake caliper.

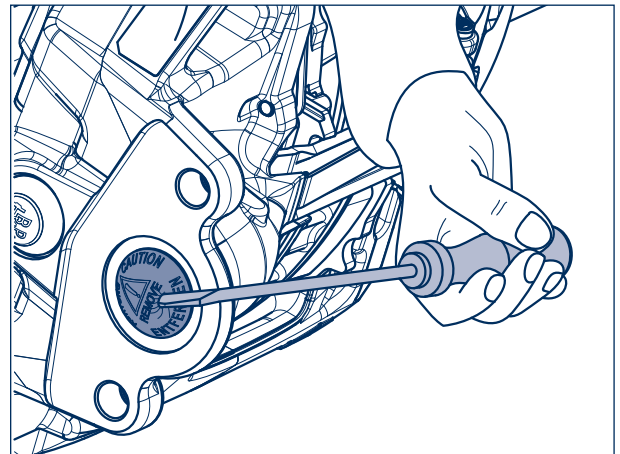

Picture 11



Note!
Clean housing and brake cylinder unit surfaces before fitting. The seal (1) and push rod chamber (2) of the brake cylinder (410, 411) must be free of dirt and moisture.

If the brake calipers are leaking, check the brake cylinders for damage. Damaged brake cylinders must be replaced.



Repair note!
Use only brake cylinders suitable for disc brakes (with "inner sealing"). (See BPW-TE 2342.0)

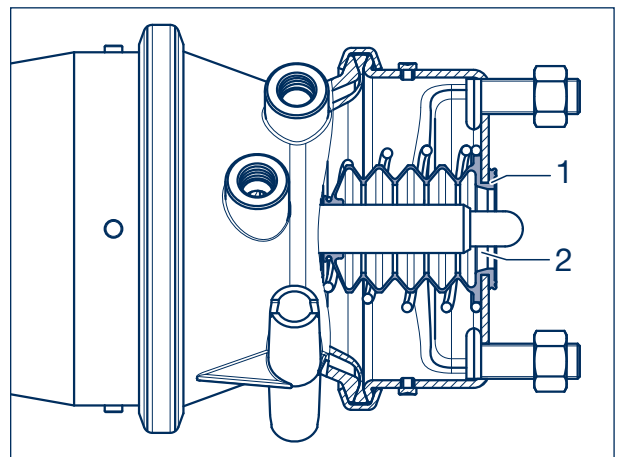

Picture 12

- [18] Before inserting the new brake cylinder (410, 411), grease the spherical cap in the lever (arrow) with **BPW ECO Disc Grease**.



Repair note!
Do not use grease containing molybdenum disulphide!

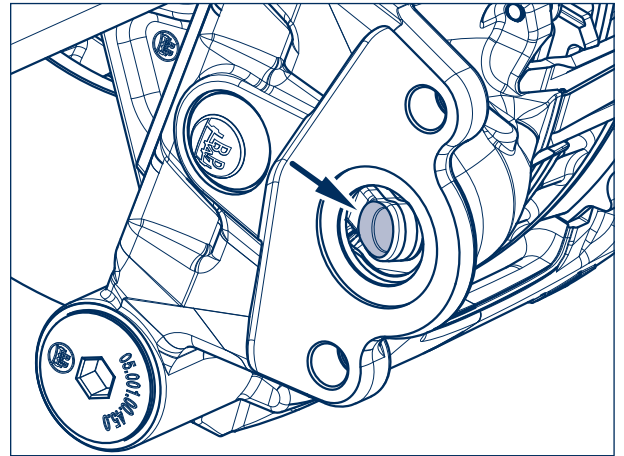

Picture 13



Repair note!
When installing the brake cylinder, ensure that it is installed in the correct position. The compressed air connection extension must be at the front and point upwards.

Ensure sufficient clearance to adjacent components.

- [19] Position the brake cylinder (410, 411) and install it using new attachment nuts (6).
Anziehdrehmoment: M :
M 16 x 1.5 - SW 24 M = **180 Nm** (180 - 210 Nm)

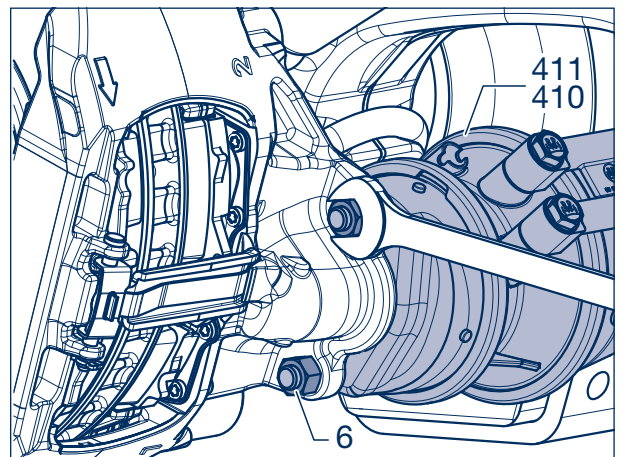

Picture 14

- [20] Remove both plugs (arrows) from the deepest drain holes of the new brake cylinder (410, 411). All other vent holes must be kept closed.

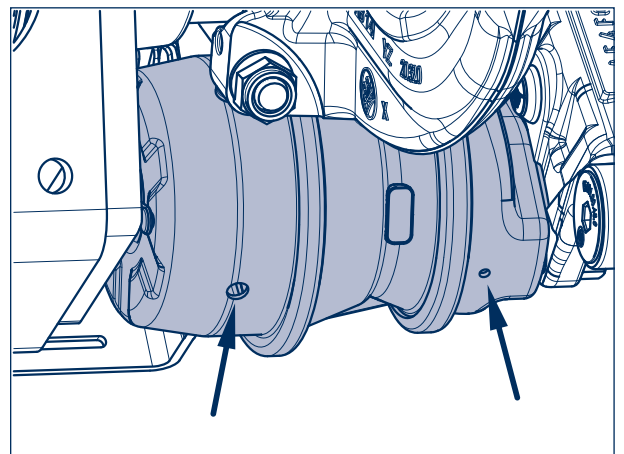

Picture 15

6 Disassembling / assembling the brake cylinders

- [21] Connect the brake lines (air connections) and check the sealing. The brake lines must be routed such that they do not twist or can rub against other components.



Repair note!

When connecting the compressed air lines to the brake cylinder, make sure the movement of the brake caliper is not obstructed by any adjacent components.



Repair note!

Do not mix up the lines!

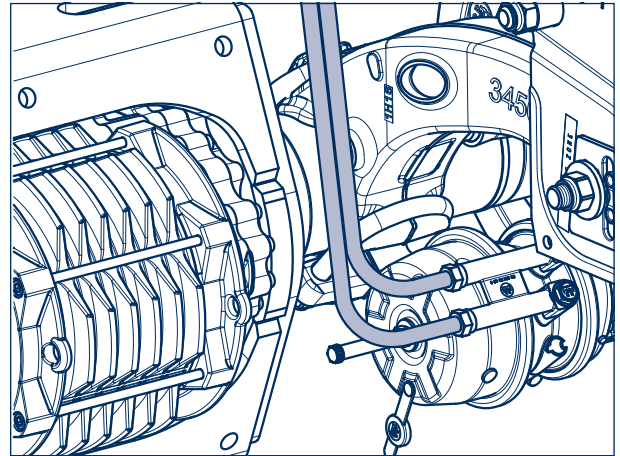

Picture 16

- [22] Release the parking brake by venting compressed air connection 1.2 with at least six bar. Loosen and unscrew the nut (3) on the spindle (4).

- [23] Remove the washer (5) from the spindle (4).

- [24] Turn the spindle (4) 90° and remove it from the brake cylinder (410, 411).

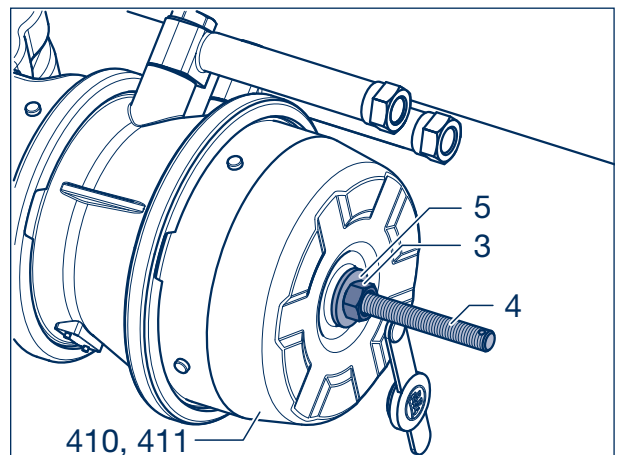

Picture 17

- [25] Close the bore hole with the lock (1) and fit the spindle (4) with the nut (3) and a washer (5) onto the brake cylinder (410, 411).

- [26] Screw on the protective cap with thread (2).

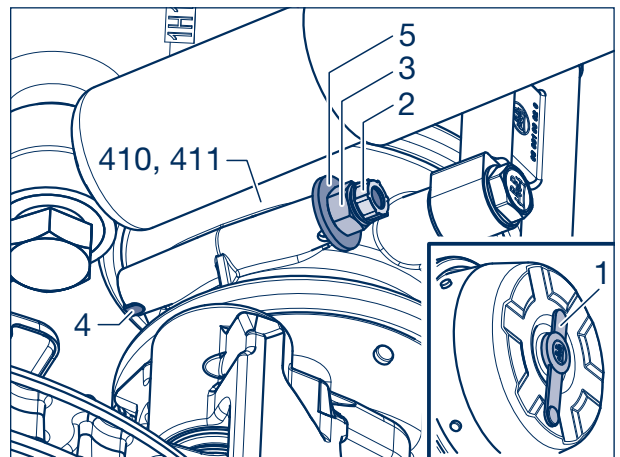

Picture 18

In other versions, screw in the spring brake bolt up to the stop and tighten it.

Anziehdrehmoment:

M = **40 Nm** (30 - 50 Nm)



Warning!

The spring-loaded brake does not function if the spring brake screw is not screwed in.



Repair note!

The air lines of the brake cylinder must be routed so that no damage can be caused by the axle beam or ePower Generator.



Repair note!

Check the functioning and effectiveness of the brake system!

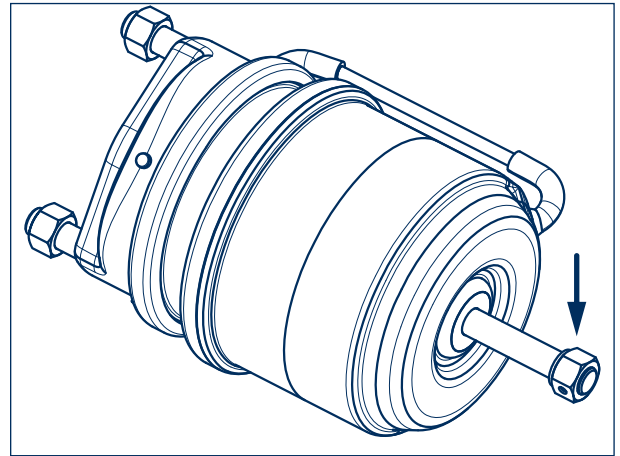

Picture 19

7 Changing the brake disc

- [1] **Prevent the vehicle from rolling away. Release the service and parking brake.**
- [2] Loosen the wheel nuts.
- [3] Support the vehicle to prevent accidents.
- [4] Raise the axle until the tyres are free.
- [5] Unscrew the wheel nuts and remove the wheel from the hub.
- [6] Knock out the wheel bolts (472).



Repair note!
 Ensure sufficient space between the bolts and the brake when knocking out the wheel bolts. Do not damage the thread of the wheel studs; use a copper hammer if necessary.

- [7] Unscrew the hexagon head screws (620, M 10, Torx E 10) from the drive shaft (615).
- [8] Pull the drive shaft with O-ring (616) out of the knuckle.

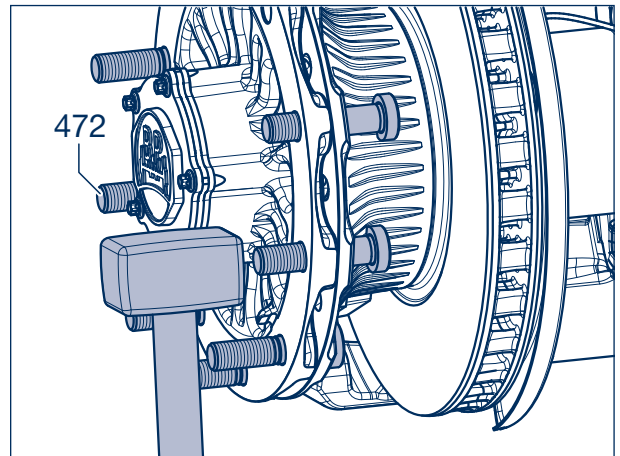

Picture 1

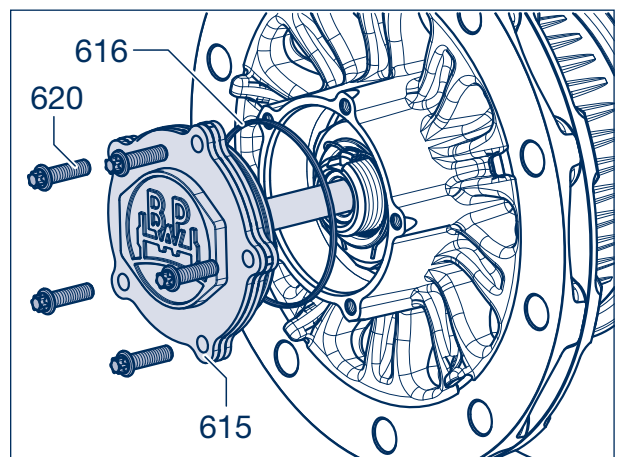

Picture 2



Warning!
DANGER OF INJURY!
 Secure the brake disc (380) with a jack or other type of support to prevent it from falling.

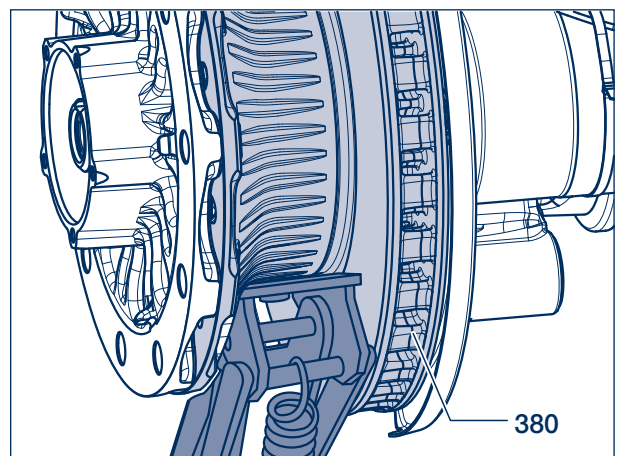

Picture 3

- [9] Remove the hooked spring ring (448) and locking piece (449) from the axle nut (446).

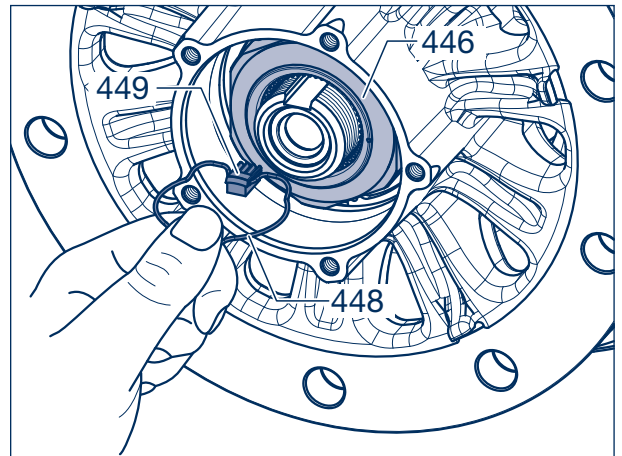

Figure 4

- [10] Unscrew the axle nut (446, SW 95) using a socket wrench for axle nuts (BPW part number: 05.364.26.05.0), pulling the complete ECO unit (434) from the bearing seats of the knuckle.



Danger!
DANGER OF INJURY!
The ECO Unit must be secured when it is removed to prevent it from falling. Use a lifting device or second person for assistance.

- [11] Remove the ECO Unit (434).

 **Disassemble ECO Unit, see workshop manual Trailer Axles with Trailer Disc Brake ECO Disc TS2.**

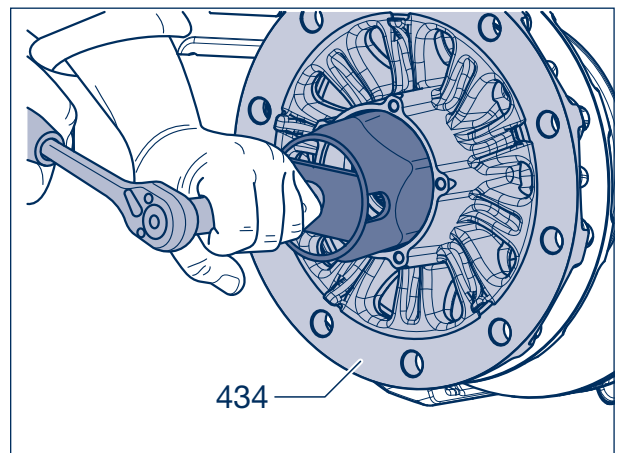

Figure 5

- [12] Remove the cap (370) with the O-ring (371) of the resetter.

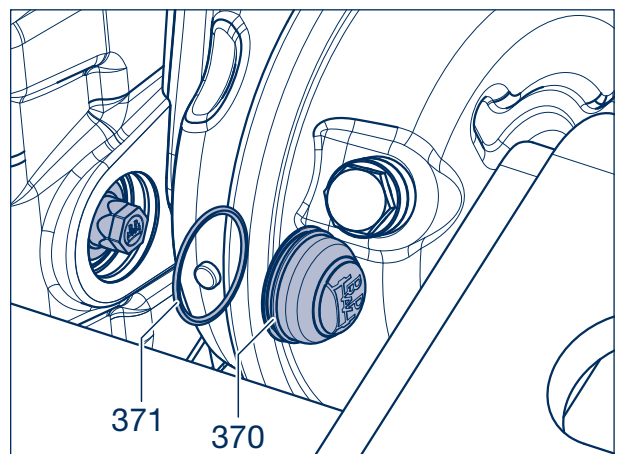

Figure 6

7 Changing the brake disc

- [13] Using a spanner (SW 13), turn the resetter counterclockwise until the bellow with pressure plate is completely reset.

Max. reset moment: 15 Nm



Repair note!

If the max. reset torque is exceeded, the adjustment can be irreparably damaged.



Attention!

Do not use a cordless screwdriver or impact wrench. Using these tools would cause considerable damage!

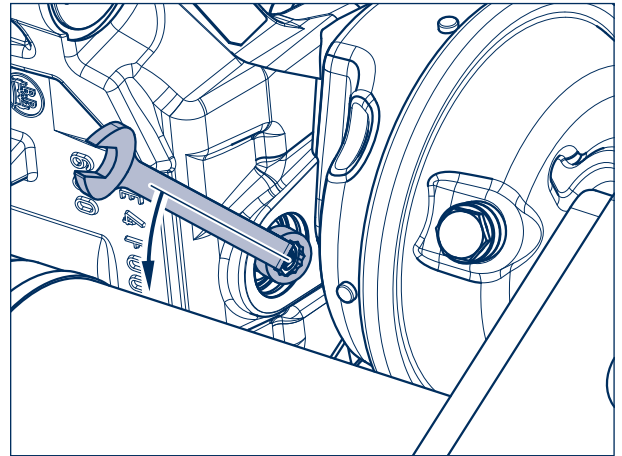

Picture 7

- [14] Pull the spring split pin (398) out of the bolt (396) with a spring plier.

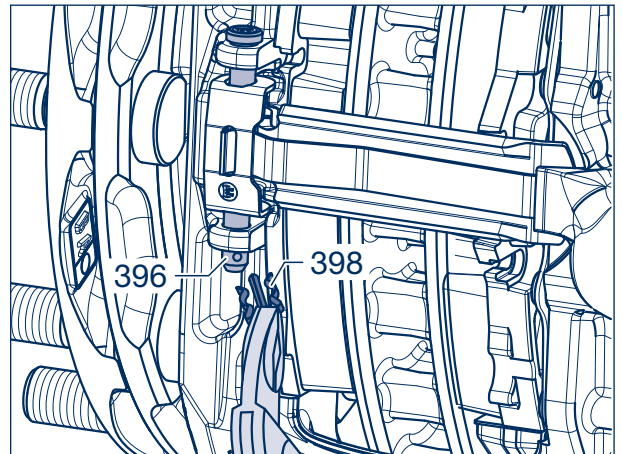

Picture 8



Caution!

Apply counter pressure to the brake linings as required so that they do not fall out of the lining groove when the pad retainer is removed.

- [15] Depress the pad retainer (395) with clamping spring (394) and remove the bolt (396) with holding clamp (397).
- [16] Remove the pad retainer (395) with clamping spring (394).

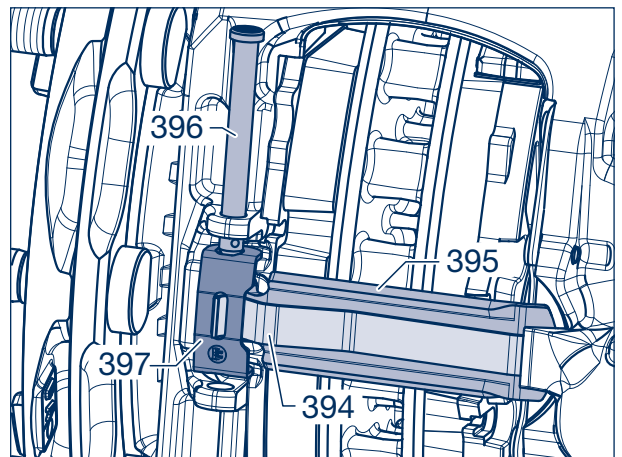

Picture 9

- [17] Remove the brake linings (390, 391).

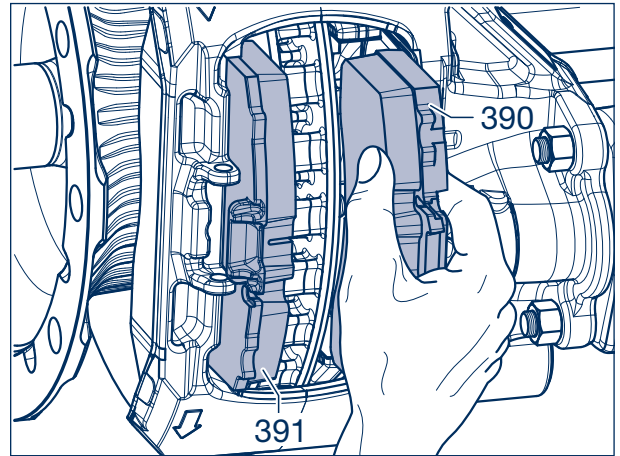

Figure 10

- [18] Tilt the brake disc (380) and remove it from the axle beam or from the brake.



Danger!
DANGER OF INJURY!
 The brake disc must be secured against falling when it is removed.
 Use a lifting device or second person for assistance.

- [19] Replace the brake disc (380).
 [20] After the brake disc (380) has been removed, check the condition of the brake; see chapter 4, pages 15 to 17.

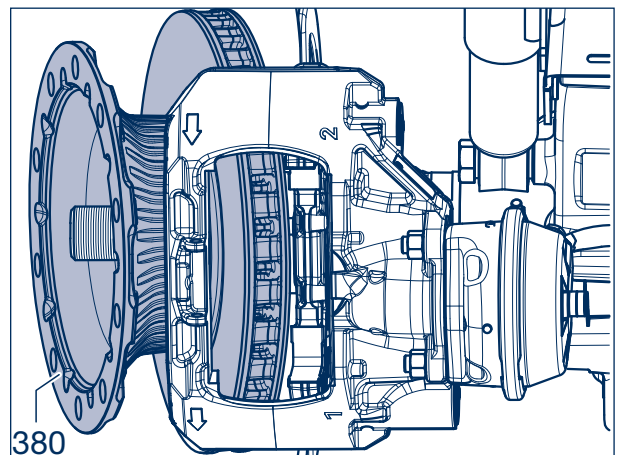

Picture 11

- [21] If no defects are found, you can continue to replace the brake disc (380).
 [22] Pry both wearing plates (389) off of the brake anchor. Clean the lining groove and the seats of the wearing plates on the brake anchor and remove corrosion.
 [23] Install both wear plates (389), use new ones if necessary.

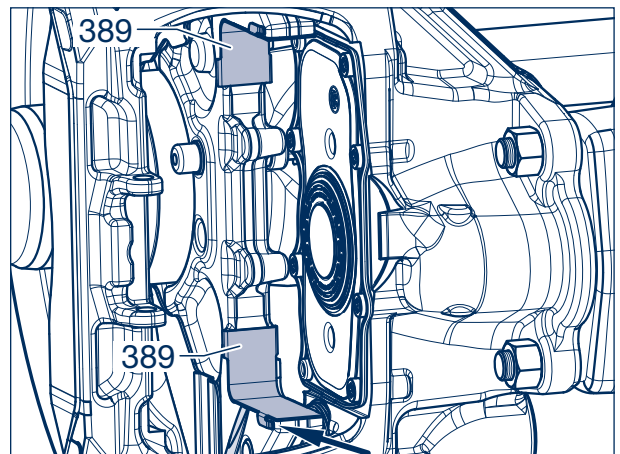

Picture 12

7 Changing the brake disc

- [24] Check sensor (570) for damage and displacement (displacement force 100 - 200 N).
- [25] If necessary, remove the holder (542) by loosening the two screws (511, SW 13).
Lubricate the clamping bush (571) and the sensor (570) with special grease (replace the clamping bush).
Mount the ABS unit and fasten it to the mounting plate of the axle beam (540) with the two screws.

Tightening torque: 25 Nm

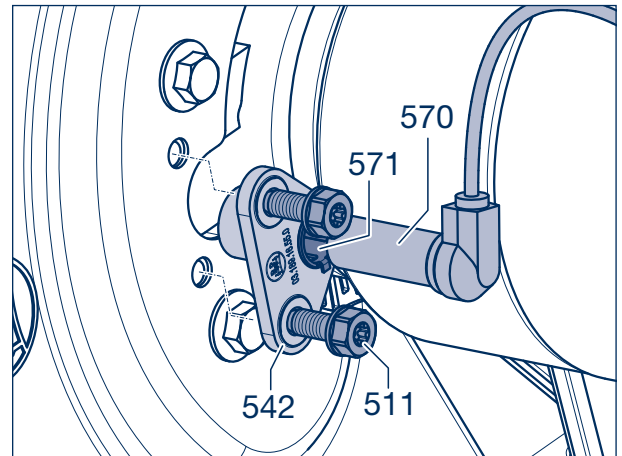

Picture 13

- [26] Before fitting hubs, always press the clamping bush (571) and the sensor (570) until they make contact.
- [27] Fasten the sensor cable to the axis body with a cable tie (569).

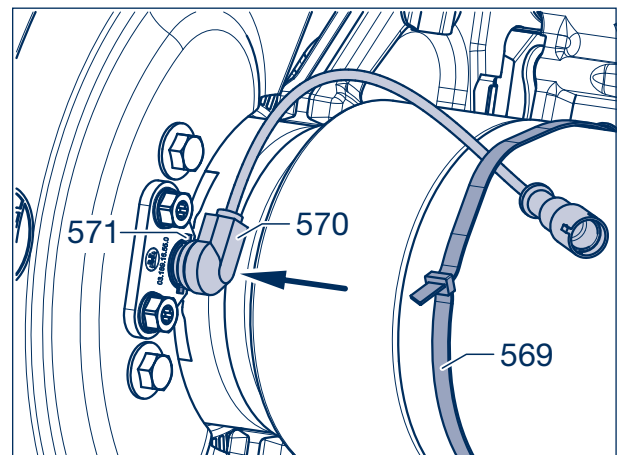

Picture 14

- [28] Use a microfibre cloth to clean the bearing seats of the axle stub (metal must be bright, dry and free of grease) and apply **Castrol White T** thinly all around using a microfleece brush. After application, no bright metal surfaces must remain. Castrol White T must not be thinned.

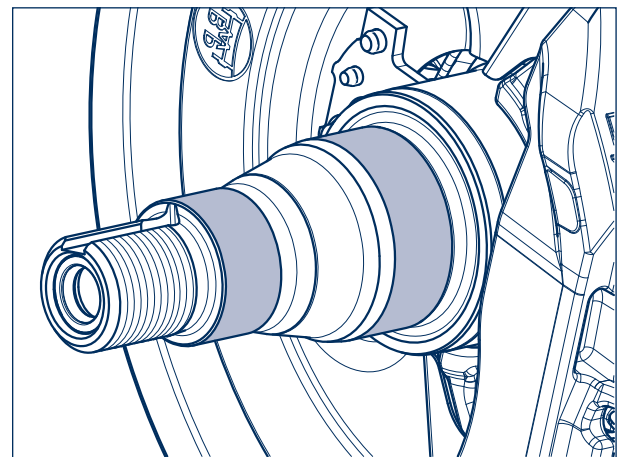

Picture 15



Repair note!
Remove any corrosion protection prior to installing the brake disc.



Repair note!
Protect the ABS sensor against damage when the brake disc is being installed.

[29] Insert the new brake disc (380) into the brake, slide it over the axle housing, and place it securely on a jack or other support.

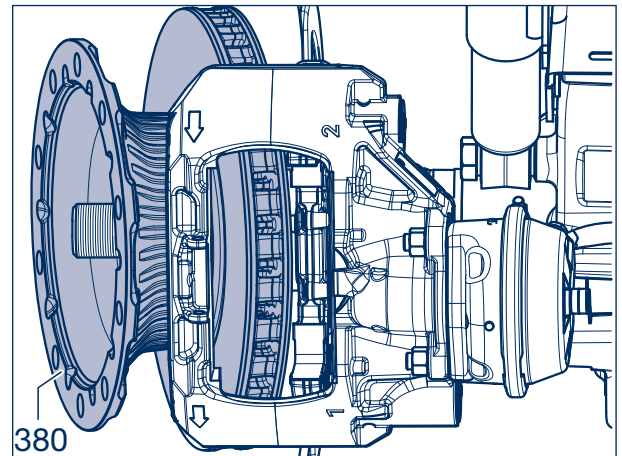

Picture 16

[30] Clean the contact surface (arrow) to the brake disc (380) at the wheel hub (435) and mount the ECO Unit (434).

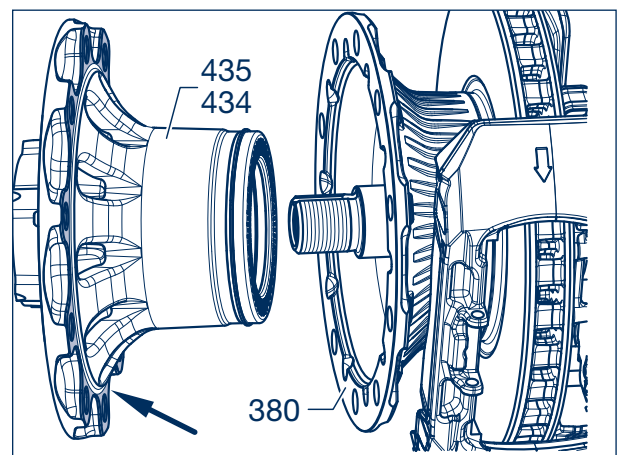
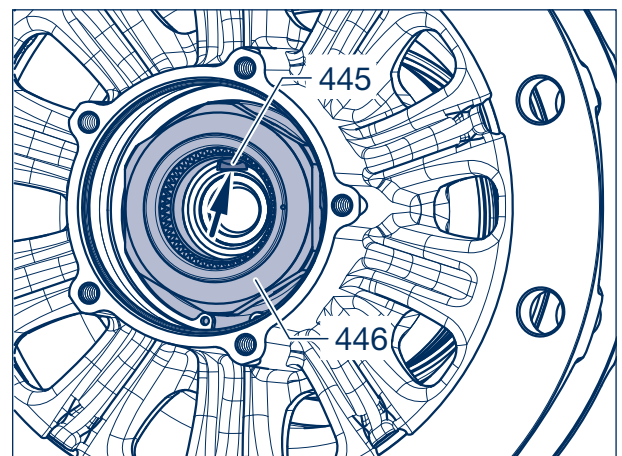

Figure 17

[31] Align the tab of the washer (445/arrow) to the groove of the stub axle by turning the axle nut (446) and gently press the ECO Unit.

[32] Push the ECO Unit centrally onto the stub axle.

[33] Tighten the axle nut (446, WAF 95).
The complete ECO Unit (434) is pulled onto the axle stub along with the axle nut.



Picture 18

7 Changing the brake disc

- [34] Tighten the axle nut (446) while continuously turning the ECO Unit (434) with a socket wrench for axle nuts (BPW No. 05.364.26.05.0). Several rotations are necessary for the tothing to slip over the axle nut. (Do not turn back the axle nut.)



Attention!
Do not use an impact wrench.

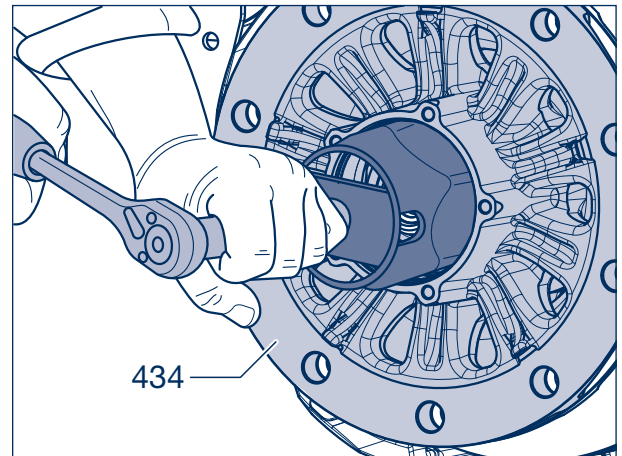

Figure 19

- [35] Fit the locking piece (449) in the groove between the axle stub and the nut (446) (do not turn back the axle nut).

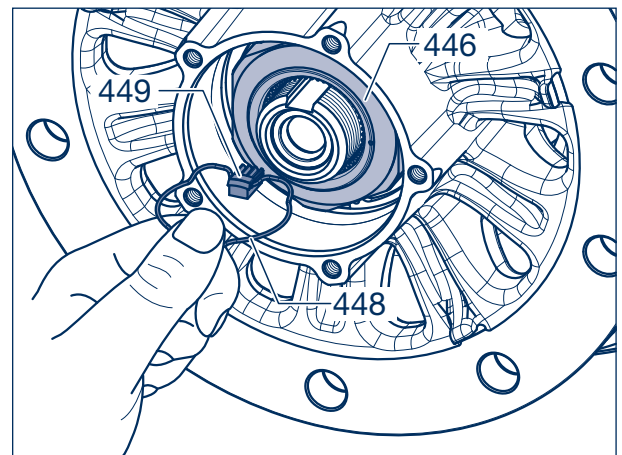
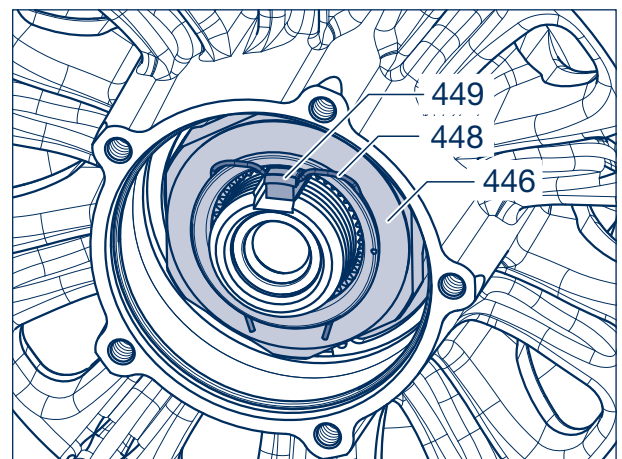

Figure 20

- [36] Insert the hooked spring ring (448) behind the formed edge of the axle nut (446).



Picture 21

- [37] Align the holes for the wheel bolts (472) of the ECO Unit (434) and the brake disc (380).
- [38] Insert the wheel bolts (472) into the brake disc / ECO Unit as far as possible. Make sure the wheel bolt head is correctly placed on the brake disc (380) (torsion protection).

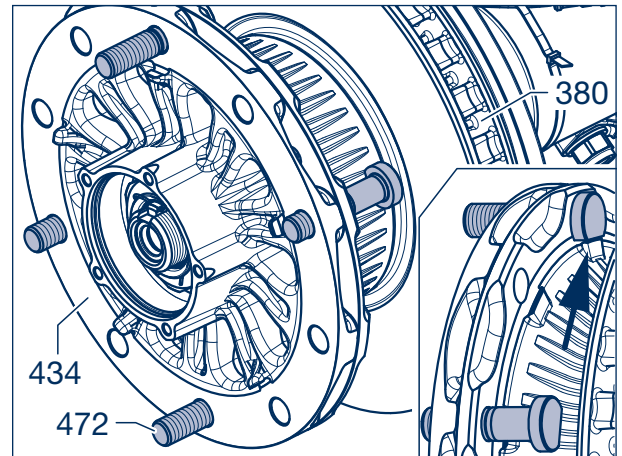

Picture 22

- [39] Tighten the wheel bolts (472) crosswise using a ring (BPW no. 02.5683.92.00) and nut until they make contact with the brake disc (380).

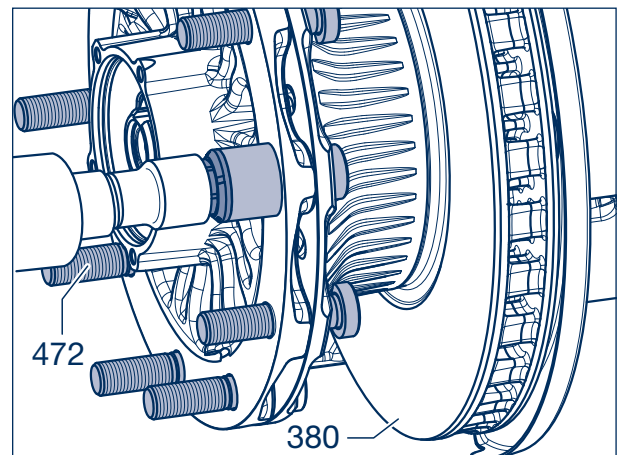

Picture 23



Repair note!
The flattened side of the wheel stud (472) must rest against the brake disc collar (380).

- [40] Remove the jack or support device.
- [41] Install brake linings (390) and wearing plates (389), then adjust the clearance; see chapter 5, page 26 - 28.

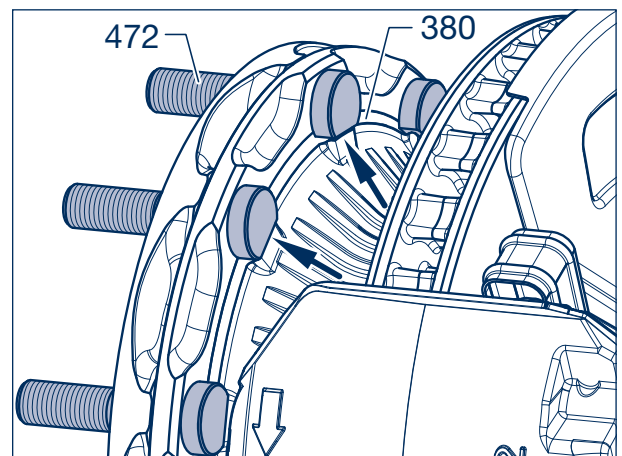

Picture 24

7 Changing the brake disc

- [42] Insert new O-ring (616) in the groove of the drive shaft (615, arrow) and coat all around with BPW special longlife grease ECO-Li^{Plus}.
- [43] Coat the teeth of the drive shaft with Renolit Paste PW.

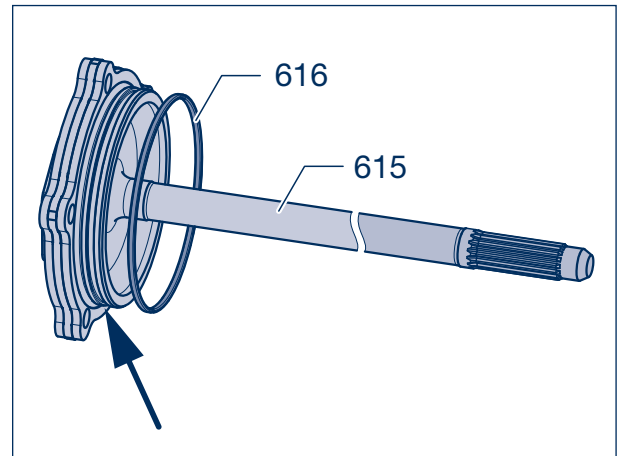

Picture 25

- [44] Lever the shaft seal (625) out of the steering knuckle.
- [45] Press the new oil seal straight into the steering knuckle (with the closed side facing outwards) until it rests against the contact surface in the steering knuckle.



Repair note!

When pressing in, take care not to damage the seal. Do not use sharp-edged objects (e.g. screwdrivers).

- [46] Coat the shaft seal with BPW special longlife grease ECO-Li^{Plus}.

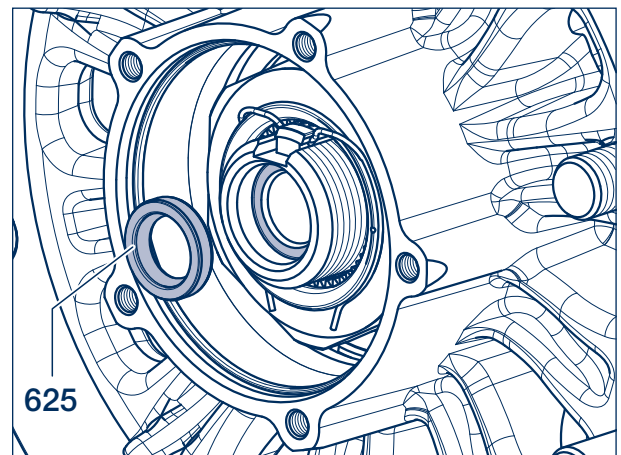

Picture 26

- [47] Insert the drive shaft (615) into the knuckle or the ePower generator.



Repair note!

Carefully insert the shaft splines so that the shaft seal is not damaged.

- [48] Mount the hexagon head screws (620, M 10, Torx E 10) and tighten them crosswise.

Tightening torque: **75 Nm** (65 - 82 Nm)

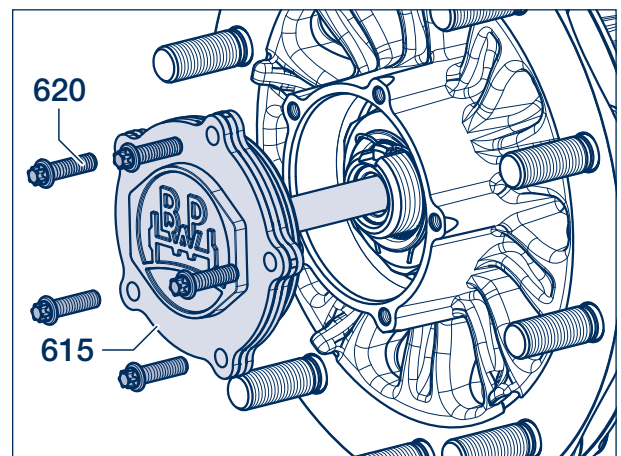

Picture 27

[49] Attach the wheels.



Repair note!
Only use wheels that have a valve outside the wheel brace.

[50] Screw on the wheel nuts (479).

[51] Lower the axle and tighten the wheel nuts to the required tightening torque.



Warning!
The tightening torque of the wheel nuts must be checked after the first run under load and, if necessary, retightened to the prescribed value.



Warning!
The braking effect of new discs and linings is only at its optimum after a few braking operations. For this reason, run in new brake linings while avoiding lengthy and unnecessarily sharp brake operations.

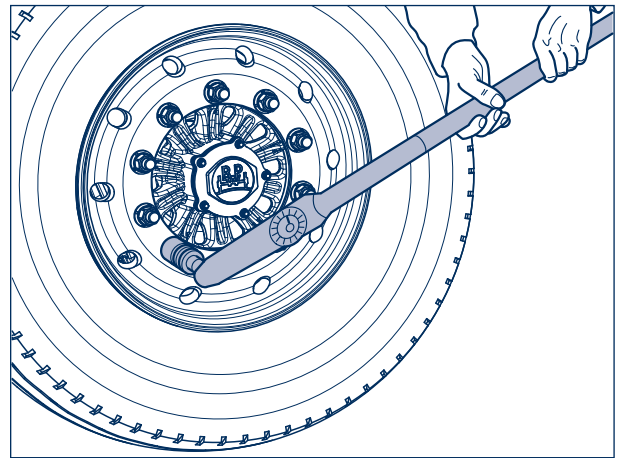

Picture 28

8 Disassembly / assembly of ePower Generators (GTU)



Danger!

DANGER OF INJURY!

During disassembly / assembly, the safety regulations for working on vehicles with high-voltage systems must be observed (see page 8). Towing the trailer is possible with the recuperation system switched off.



Repair note!

The replacement of the ePower generator (GTU) must take place on a pit. A second mechanic and a jack should be available. The weight of a GTU is approx. 90 kg.



Repair note!

For the disassembly of the GTU, the axle beam should be brought into the horizontal position. This ensures that the mounting device, if required, is also seated horizontally. This facilitates the exchange of the GTU.

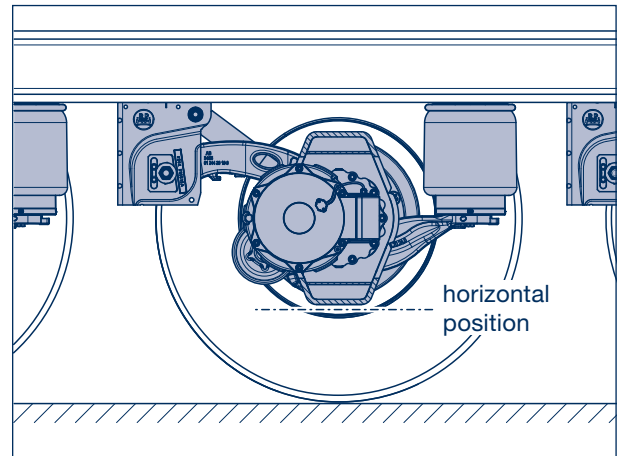

Picture 1

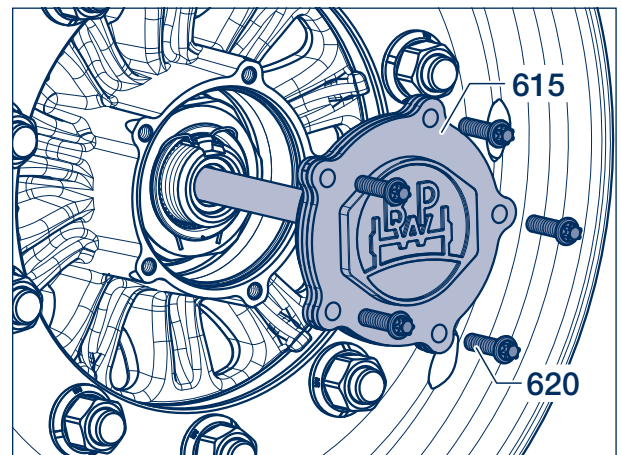

Picture 2

- [1] Unscrew the hexagon head screws (620, M 10, Torx E 10) from the drive shaft (615).
- [2] Pull the drive shaft with O-ring (616) out of the knuckle.



Repair note!

If the ePower axis has to be turned to the "back position" during service / repair, make sure that small amounts of oil (droplets) can drip from the vent valve (607) of the GTU (605). Ensure that any dripping is caught.

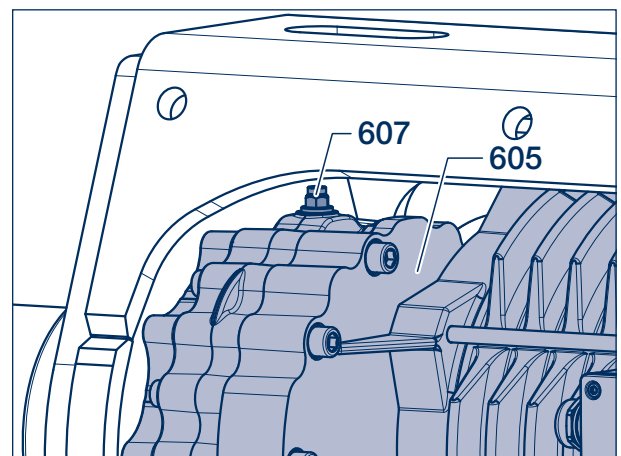

Picture 3

- [3] Disconnect the connector on the cable (1) of the encoder sensor in the ENERGe PACK and pull it to the GTU.

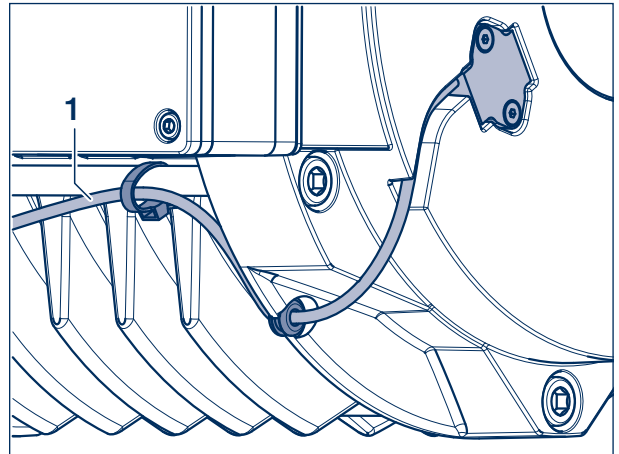

Picture 4

Disconnect all connection cables of the GTU

- [4] Unscrew the hexagon socket screws (2, SW 4) from the terminal box and remove the cover (3) with seal (4).
Store the components in a clean place.

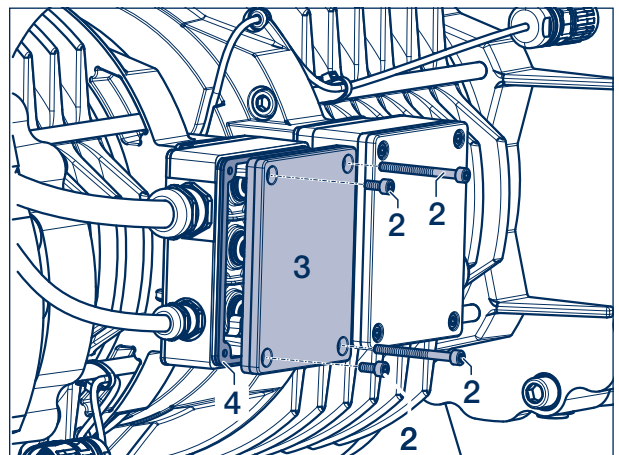

Figure 5

- [5] Cut open the cable tie and remove it.



Repair note!
Do not damage cables and butt connectors.

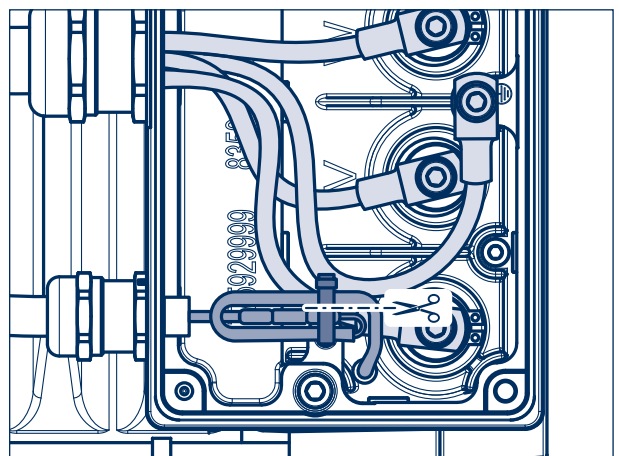

Figure 6

8 Disassembly / assembly of ePower Generators (GTU)

- [6] Cut open both butt connectors at the marked points. The cables coming out of the GTU should be preserved as long as possible.

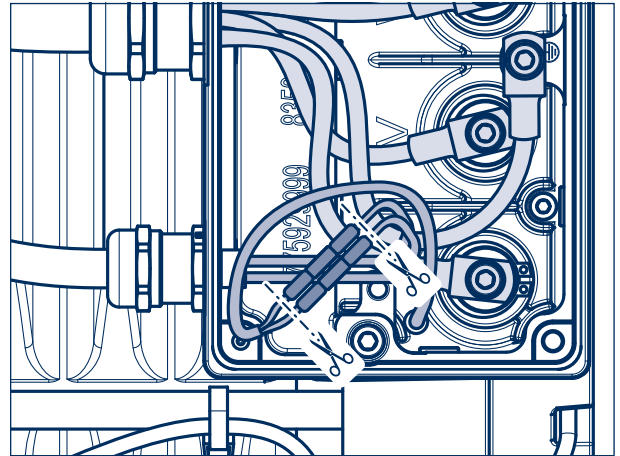

Figure 7

- [7] Unscrew the PE screw (arrow, M 5 x 10, SW 4) of the HV AC cable from the terminal box and remove it from the cable lug.
- [8] Reattach screw with washer and serrated lock washer temporarily to terminal box.

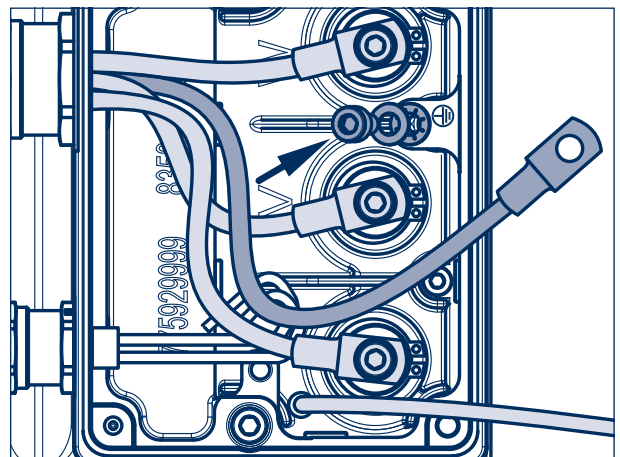
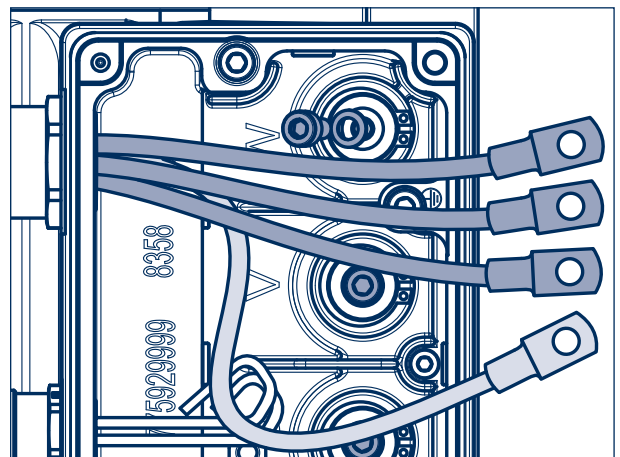

Figure 8

- [9] Unscrew screws U, V, W (M 5 x 12, SW 4) of the HV AC cable from the terminal box and remove from the cable lug.
- [10] Reattach screws with washers temporarily to the terminal box.



Picture 9

- [11] Open the PG screw connections (M 25 x 1.5 - SW 30 / M 16 x 1.5 - SW 20) and pull the connection cable out of the terminal box.



Attention!
When leading the cable out of the PG gland, make sure that the shield is not damaged.
Cables with damaged shield must be replaced with new ones.

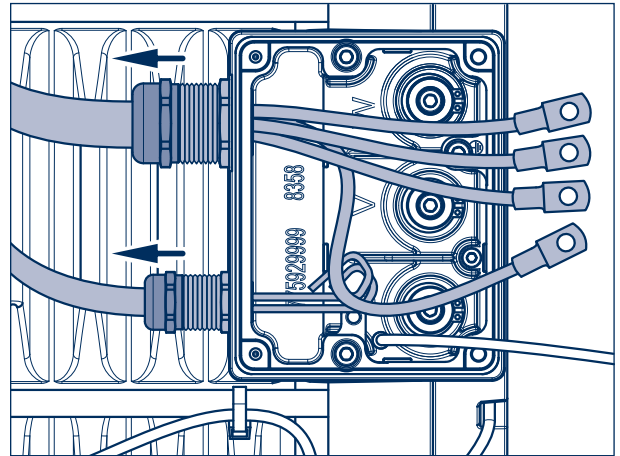
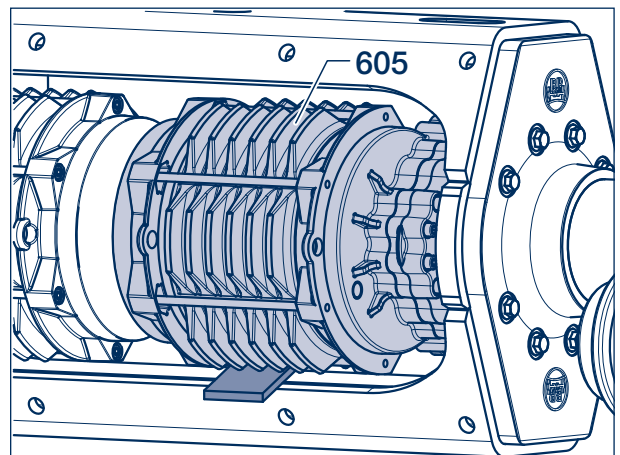

Figure 10



Danger!
DANGER OF INJURY!
The GTU must be secured against falling down before it is brought down. Use a hoist or second person for assistance. If necessary, mount the generator underneath. The weight of a GTU is approx. 90 kg.

BPW recommends the use of the BPW mounting device. This can be borrowed from BPW on request.



Picture 11

- [12] Unscrew all locking screws (608, SW 16), except for one screw, from the axle housing.

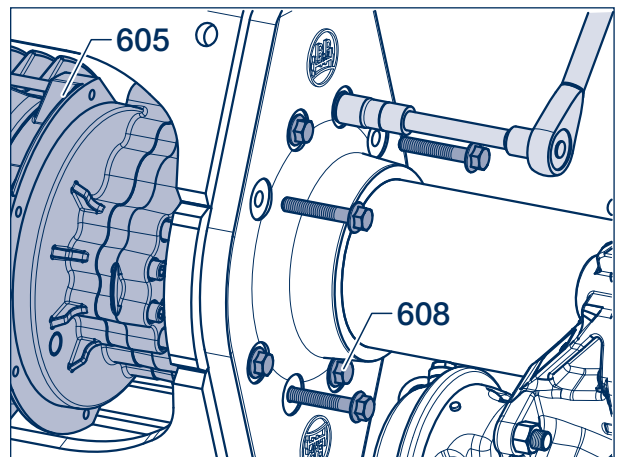

Picture 12

8 Disassembly / assembly of ePower Generators (GTU)



Caution!
When attaching the mounting device, make sure that it is hooked in securely (hook both hooks onto the axle beam) and that hands and fingers are not crushed.

- [13] Hook the mounting device onto the axle beam from the front, centered under the GTU. If necessary, remove the front holder (1) by unscrewing the hexagon head screws (3, SW 19) with the fastening rod (2).

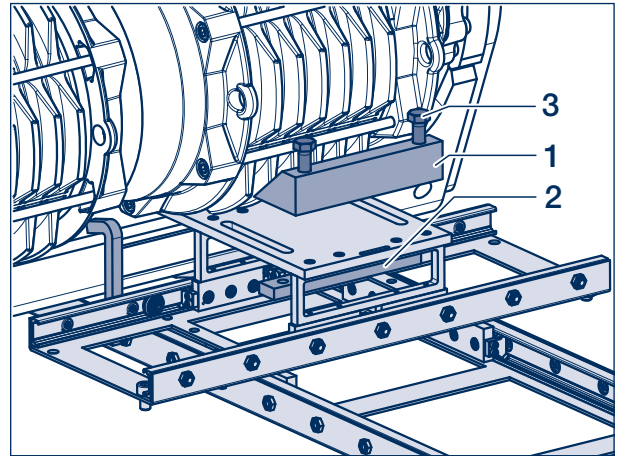
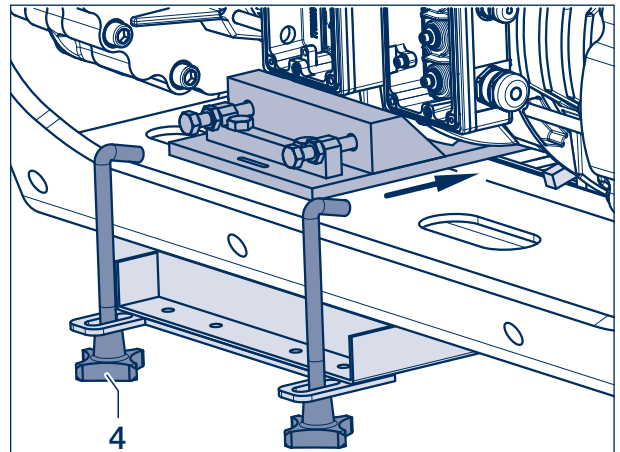

Figure 13

- [14] Secure the mounting device to the axle beam from behind with 2 clamping screws (4).
- [15] Slide the carriage on the mounting fixture in the direction of the arrow until it rests against the GTU.
- [16] Mount the front holder (1) to the mounting device using 2 hexagon head screws (3, SW 19) and the fastening rod (2) (see Fig. 13).



Picture 14

- [17] Unscrew the last mounted fastening screw (608, see also work step [12]) from the GTU. In the process, the generator is released and placed on the carriage of the device.



Caution!
When placing the GTU and then moving the carriage on the mounting device, make sure that hands and fingers are not crushed.

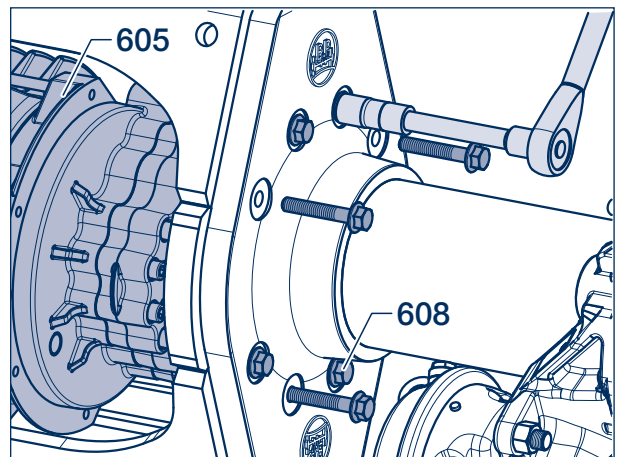

Picture 15

- [18] Place the tensioning strap over the GTU and fasten it to the carriage of the mounting device.
- [19] Remove the GTU with the carriage from the axis housing.
- [20] Position the jack in front of the mounting device.
- [21] Loosen the tensioning strap and push or roll the GTU onto the jack.



Warning!

When transferring the GTU from the mounting fixture to the jack, as well as during the subsequent exchange, a second person must provide assistance.

It is recommended that one person in front of the axle guides the generator and the second person behind the axle "rolls" or pulls the generator onto the jack. During replacement, do not step under the mounting device.

Attention, risk of accident!

- [22] Move the GTU in front of the first axle with the jack and pull it out to the side.
- [23] Remove the O-ring (606) from the groove of the axle housing.
- [24] Thoroughly clean the contact surfaces of the GTU and the axle housing (incl. groove for O-ring).
- [25] Insert new O-ring.
- [26] Coat the O-ring with BPW special longlife grease ECO-Li^{Plus} and insert it in the groove on the axle housing.
- [27] Check the toothing in the GTU for contamination, clean if necessary and coat with Renolit Paste PW.

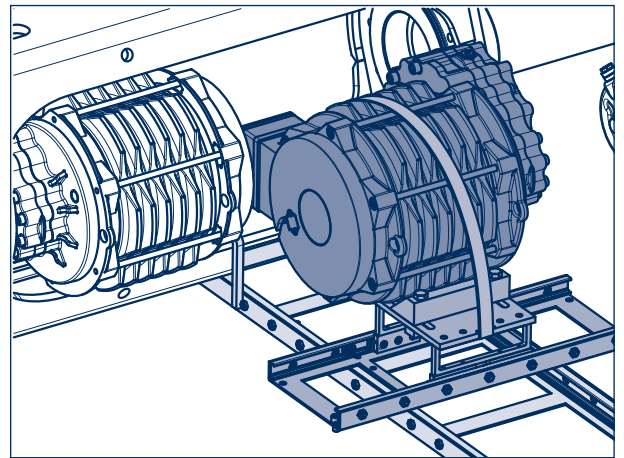

Figure 16

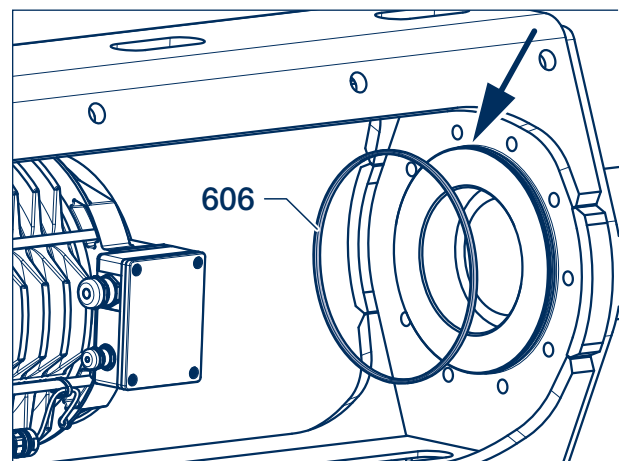
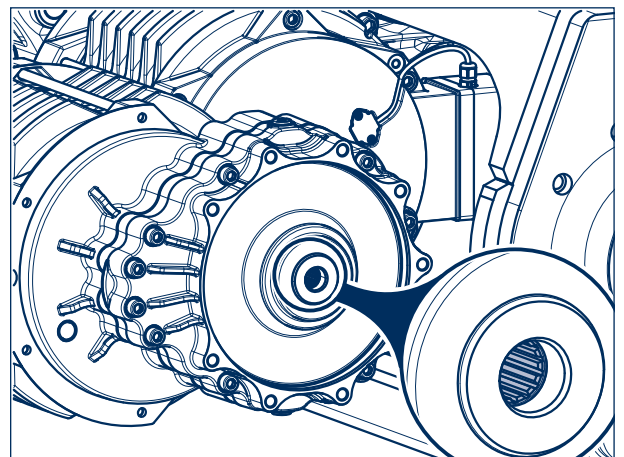

Figure 17



Picture 18

8 Disassembly / assembly of ePower Generators (GTU)



Repair note!

When replacing a GTU (605) with a new GTU, be sure to replace the upper oil drain plug with a breather valve (607). Tightening torque: 11 Nm

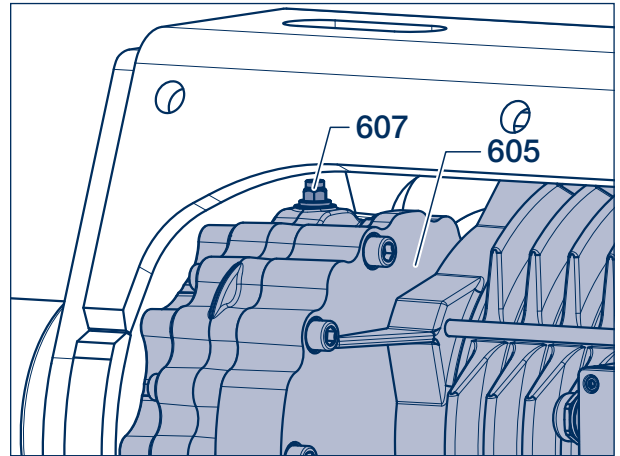

Figure 19

[28] Carry out assembly of the GTU in reverse order. Place the generator on the carriage of the mounting device via the jack.

[29] Place the GTU on the carriage so that the terminal box is in the horizontal position.

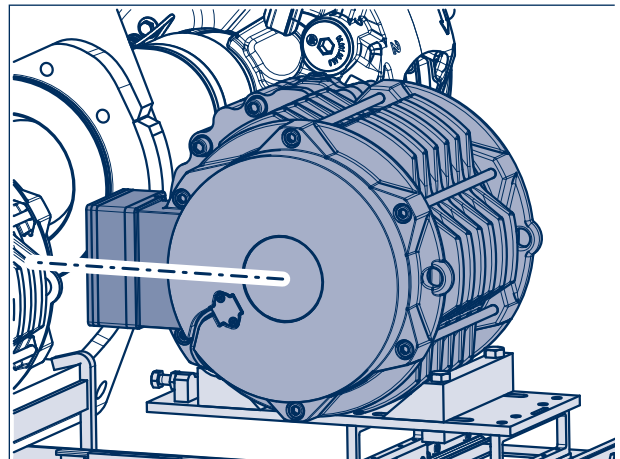

Figure 20

[30] Slide the GTU (605) over the O-ring (606). If necessary, use a mounting lever to push the generator into the correct position. The vent valve or the transport plug (607) must point upwards.

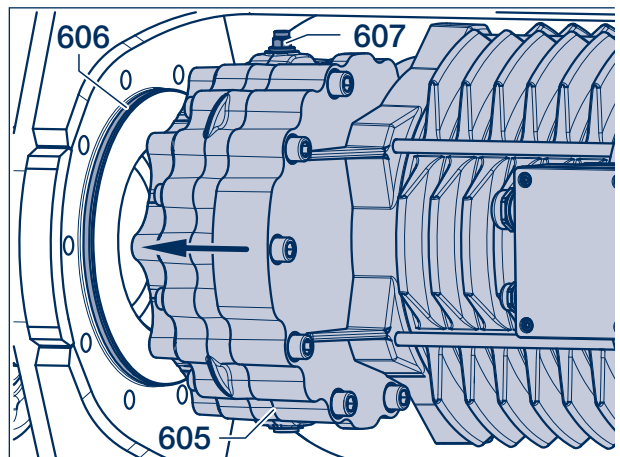

Figure 21

**Repair note!**

The threads for the fastening screws in the GTU must be cleaned with a tap before each assembly and recut if necessary.

New locking screws (608) must be used for assembly.

- [31] Install new locking screws (608, SW 16) and tighten them in the correct sequence (see Fig. 15) to the specified tightening torque of **103 Nm** (94 - 112 Nm).

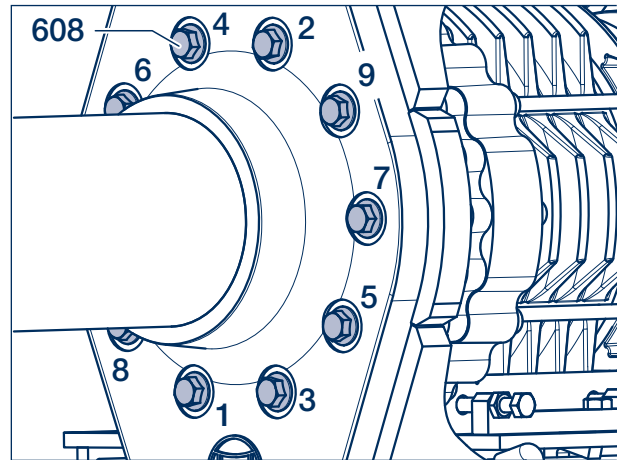

Figure 22

- [32] Loosen the clamping screws (4) of the mounting device and remove the device from the axle beam, if necessary dismantle the front holder (see Fig. 13).

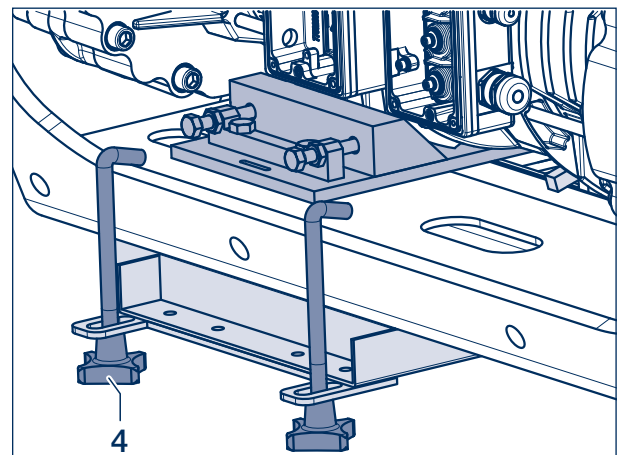

Figure 23

- [33] Route cable (1) with connector from the encoder sensor to the ENERGE PACK and connect.

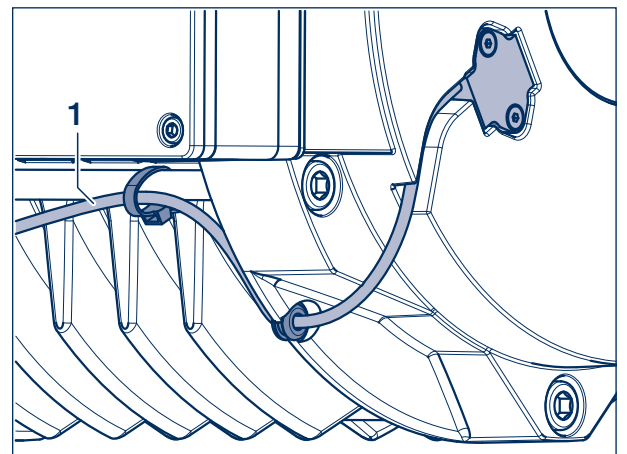
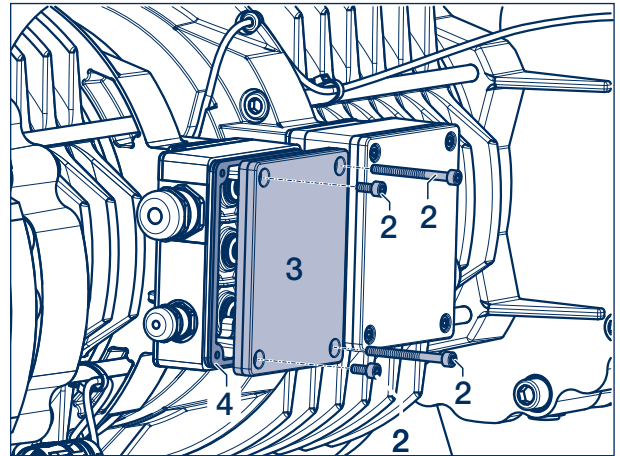

Figure 24

8 Disassembly / assembly of ePower Generators (GTU)

- [34] Unscrew the hexagon socket screws (2, SW 4) from the terminal box and remove the cover (3) with seal (4). Store the components in a clean place.



Picture 25

- [35] Insert the temperature cable and HV cable through the PG gland into the terminal box. Ensure sufficient length and orientation of the cable ends!
- [36] Tighten the nut of the PG screw connection to the specified tightening torque.

Anziehdrehmoment:

M 25 x 1.5 (SW 30)	12 Nm
M 16 x 1.5 (SW 20)	10 Nm

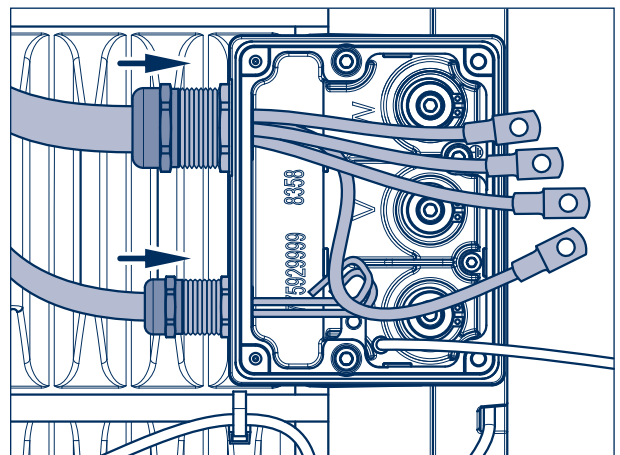

Picture 26

- [37] Unscrew screws (1) with washers (2, 3) from the terminals U, V, W of the terminal box.
- [38] Connect the HV AC cable to the terminals U, V, W of the terminal box with the disassembled screws and washers. Connect the cable cores as follows

Connection W: wire blue
 Connection V: wire black
 Connection U: wire red



Repair note!
 When assembling the cable cores, it is necessary to pay attention to the correct sequence of the components.

- 1 = Screw M 5 x 12
 2 = Lock washer S5
 3 = Washer A5 DIN 125
 4 = Ring tongue of the cable core

Tightening torque: 4 Nm

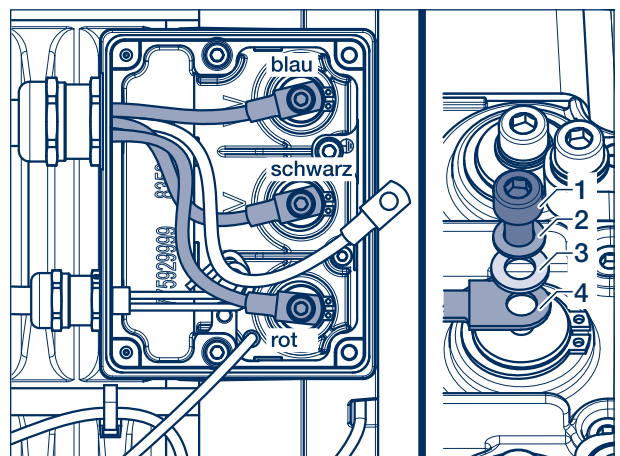

Figure 27

- [39] Unscrew the PE screw (5) with the spring washer (6) from the connection on the terminal box.
- [40] Place the ring tongue (7) of the PE wire on the spring washer (8) and screw it to the terminal box with the screw and spring washer.

Tightening torque: 3 Nm

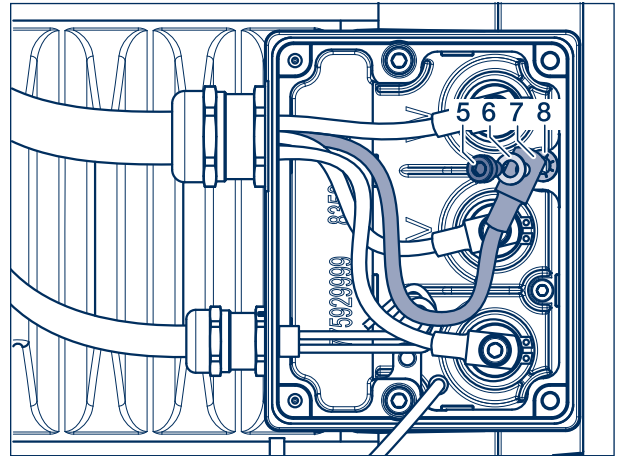

Figure 28

- [41] Remove insulation approx. 8 mm from both wires of the temperature cable.
- [42] Crimp both wires of the temperature cable to the butt connectors and then shrink both ends of the butt connector with a hot air gun.

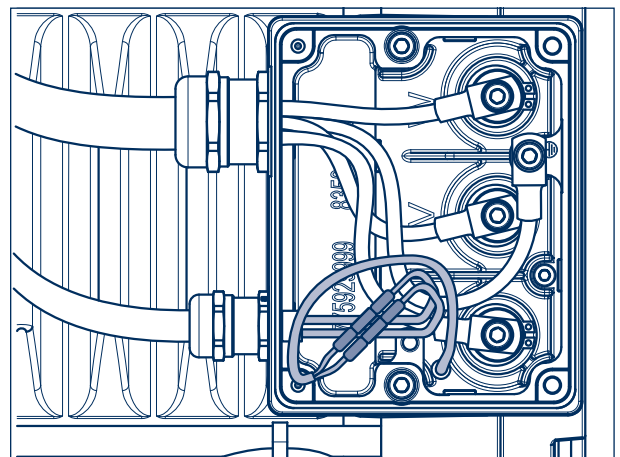
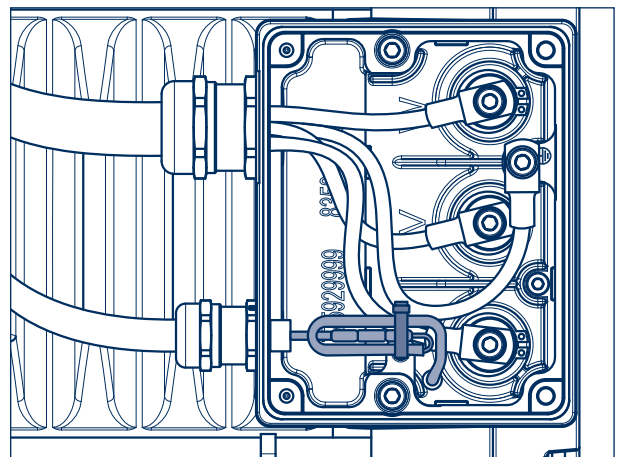

Figure 29

- [43] Place temperature cable in a "loop" and secure to terminal box housing with a cable tie. Do not bend or crush the cables.



Danger! Carry out insulation resistance measurement: Perform measurement in the terminal box of the replaced GTU with a test voltage of 500 V, by competent personnel, all-phase (U, V, W, PG). Observe safety regulations during measurement. The measured value must be above 425 kΩ.



Picture 30

8 Disassembly / assembly of ePower Generators (GTU)

- [44] Clean the seal of the terminal box cover if necessary and insert it into the cover. Porous or damaged seals must be replaced!

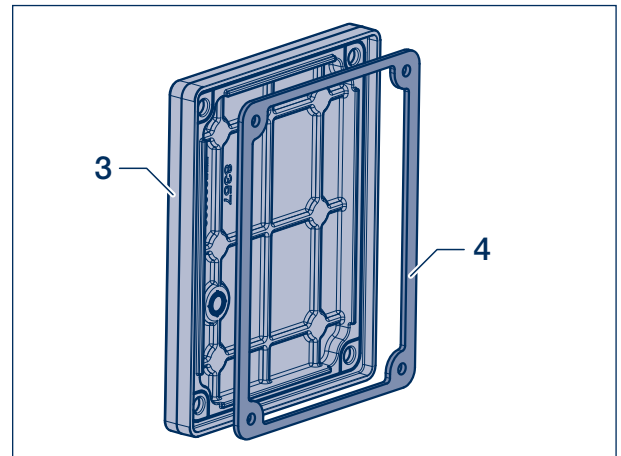

Figure 31

- [45] Place the terminal box cover (3) with seal (4) on the terminal box.
- [46] Install long hexagon socket head screws (2, SW 4) in the center of the axle, short screws facing outward and tighten.

Tightening torque: 3 Nm



Warning!

Contact resistances: Measurement from each GTU to the ground point in the ENERGe PACK, as well as from the terminal box cover to the GTU housing with a test current greater than 0.2 A. The measured value must be less than 0.1 Ω.

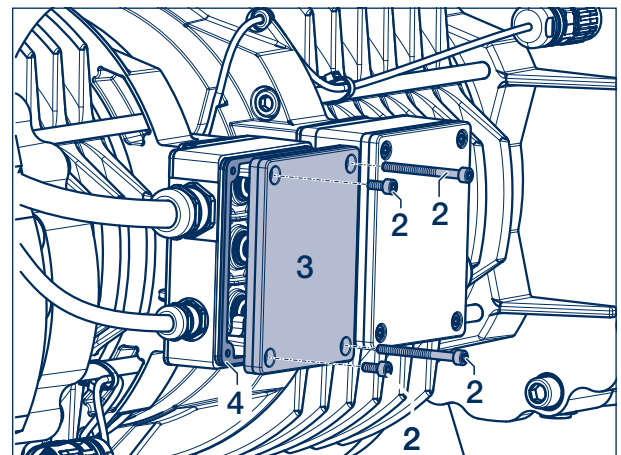
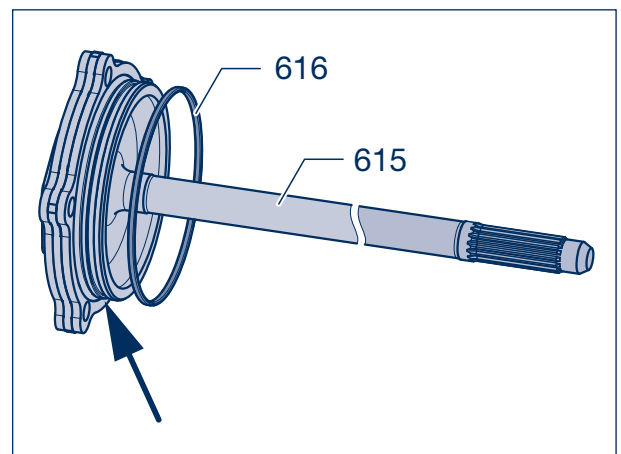

Figure 32

- [47] Insert new O-ring (616) in the groove of the drive shaft (615, arrow) and coat all around with BPW special longlife grease ECO-Li^{Plus}.
- [48] Coat the teeth of the drive shaft with Renolit Paste PW.



Picture 33

- [49] Lever the shaft seal (625) out of the steering knuckle.
- [50] Press the new oil seal straight into the steering knuckle (with the closed side facing outwards) until it rests against the contact surface in the steering knuckle.



Repair note!

When pressing in, take care not to damage the seal. Do not use sharp-edged objects (e.g. screwdrivers).

- [51] Coat the oil seal with BPW special longlife grease ECO-Li^{Plus}.

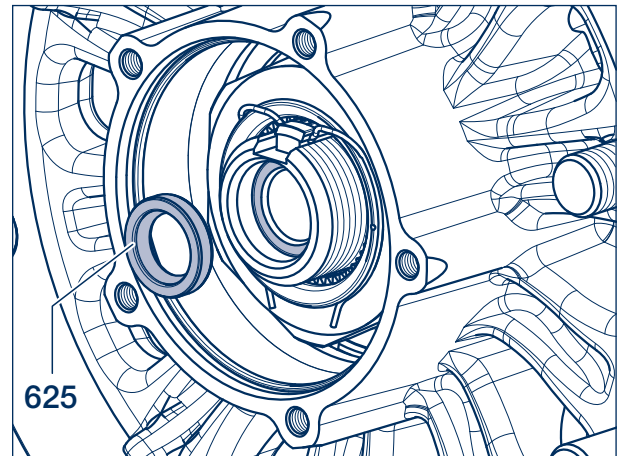

Figure 34

- [52] Insert the drive shaft (615) into the stub axle or the GTU.



Repair note!

Carefully insert the shaft splines so that the shaft seal is not damaged.

- [53] Mount the hexagon head screws (620, M 10, Torx E 10) and tighten them crosswise.

Tightening torque: **75 Nm** (65 - 82 Nm)



Warning!

The braking effect of new discs and linings is only at its optimum after a few braking operations. For this reason, run in new brake linings while avoiding lengthy and unnecessarily sharp brake operations.

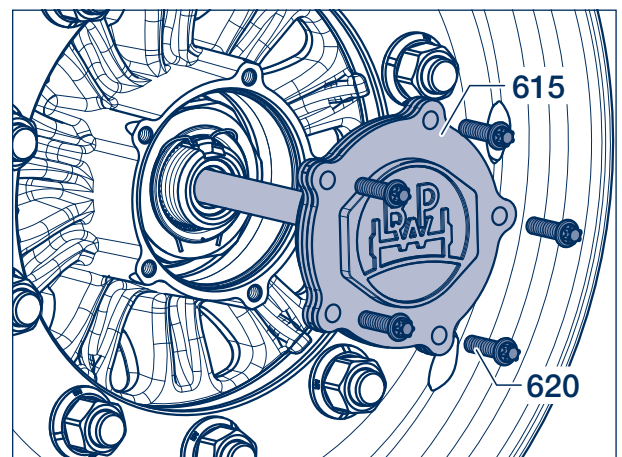

Picture 35

9 Encoder sensor replacement

- [1] Remove the cable tie (1) of the sensor cable fixation.
- [2] Remove the rubber grommet (2) with sensor cable from the holder on the GTU.
- [3] Screw countersunk screws (3) with hexagon socket (M 4 x 14, SW 2.5, DIN 7991) out of the sensor (4) / GTU.



Repair note!
After removing the sensor, the generator must be protected from foreign matter and moisture ingress.

- [4] Position sensor with O-ring on GTU. Make sure that the seal is seated correctly.
- [5] Coat new countersunk screws with Loctite 243.
- [6] Mount the screws and tighten them with a torque of 1.5 Nm.
- [7] Press the rubber grommet (2) with sensor cable into the receptacle on the GTU.
- [8] Fix the sensor cable to the GTU with a cable tie.

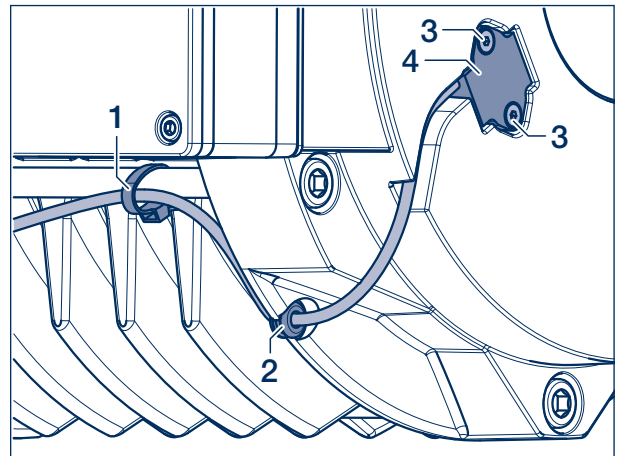

Picture 1

BPW is a globally leading manufacturer of intelligent running gear systems for trailers and semi-trailers. As an international mobility and system partner, we offer a wide range of solutions for the transport industry from a single source, from axle to suspension and brake to user-friendly telematics applications.

We thereby ensure outstanding transparency in loading and transport processes and facilitate efficient fleet management. Today, the well-established brand represents an international corporation with a wide product and service portfolio for the commercial vehicle industry. Offering running gear systems, telematics, lighting systems, composite solutions and trailer superstructures, BPW is the right system partner for automotive manufacturers.

BPW, the owner-operated company, consistently pursues one target: To always give you exactly the solution which will pay off. To this end, we focus our attention on uncompromising quality for high reliability and service life, weight and time-saving concepts for low operating and maintenance costs as well as personal customer service and a close-knit service network for quick and direct support. You can be sure that with your international mobility partner BPW, you always use the most efficient method.

Your partner on the path to economic viability



BPW Bergische Achsen Kommanditgesellschaft

Postbox 12 80 · 51656 Wiehl, Germany · Phone +49 (0) 2262 78-0
info@bpw.de · www.bpw.de