



RTS-RIEGERTEAM.DE BPW-Messeflyer Agritechnica 15121101 e

WE PROVIDE THE ECONOMICAL ROUTE!

BPW is Europe's leading manufacturer of intelligent running gear systems for drawbar trailers and semi-trailers in the utility vehicle and agricultural sector. From the axle via the suspension and brake to the electronic braking system, we can provide you with complete one-stop running gears. As an owner-managed company, BPW is committed to one goal: to always offer you precisely the solution which pays off for you in the end.

To this end, we focus on total quality to ensure high reliability and life expectancy, weight- and time-saving concepts ensuring lower operating and maintenance costs as well as personalised customer service and a tight-knit service network to provide quick and direct support. You can be sure you are taking the economical route with BPW.

QUALITY

NEEDS A

STRONG

PARTNER





STRONG QUALITY TO REAP SUCCESS

Expanded range of tasks, increased speed, more payloads – the demands placed on vehicles and machines used in agriculture are increasing. Our response to this is based on four developments, which will equip you to meet these new demands: our agricultural axle for 80 km/h, our one cylinder steering axle, our heavy duty bogie suspension and our ECO Tronic EBS electronic braking system.

In addition to individual components, BPW also supplies fully equipped suspensions, which can be flexibly configured – including the brake system, tubing or hosing as well as the steering components of pneumatic and hydro-pneumatic suspensions. The suspension can be provided with a complete auxiliary frame already mounted, considerably reducing the production time on the part of the vehicle manufacturer.

With BPW, you are therefore assured of high quality, which is up to meeting all the hard demands of every-day working life. This is underpinned by the highest production standards, comprehensive testing as well as the optimum availability of original replacement parts due to our world-wide coverage of 3,100 BPW service stations. You can rest assured: your trailer is perfectly set up for you to reap success.

HIGH SPEED

BPW AGRICULTURAL AXLE FOR 80 KM/H

Setting quality as the pace: the new agricultural axle for 80 km/h from BPW can handle increased demands for performance, speed and deployment periods. Especially for the professional custom farmer available for 24 hour working (e.g. bio-gas plants) in the fields and on the road, it is as if it had been made to ensure you gain benefits in time and thus in turnover.

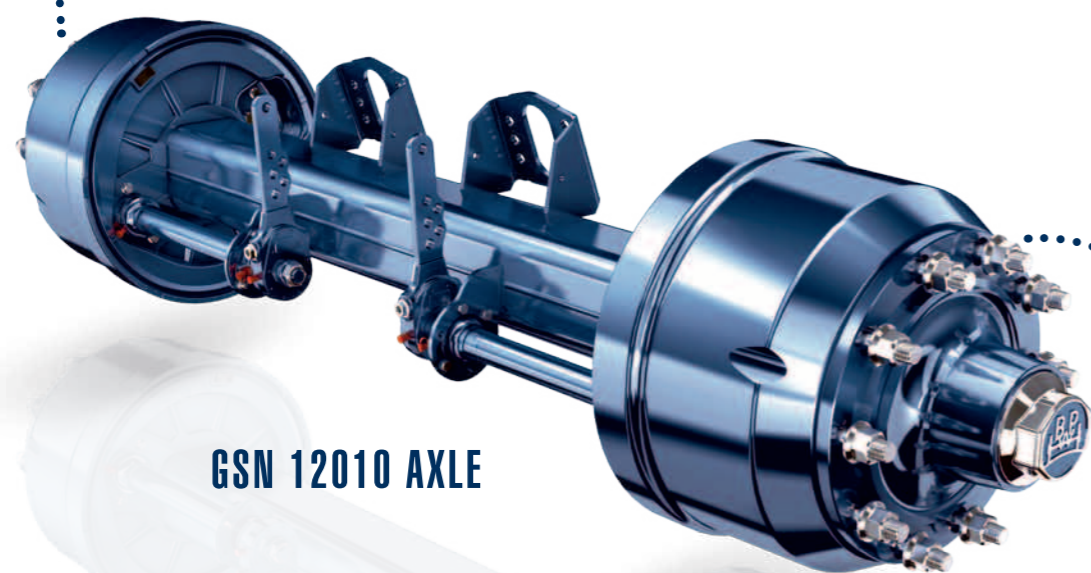

GSN 12010 AXLE

Your advantages at a glance:

- Suitable for up to 80 km/h
- Ideal for use on the road or in light terrain through assembly or air suspension
- Increased wear volume of the brake linings due to S-cam brakes
- Preparation for TPS (tyre pressure control system) option
- Optimum adjustment to use through single or twin wheels
- For agricultural tiring up to 30.5 inches

POWER STEERING

BPW ONE CYLINDER STEERING AXLE WITH COMBINED CYLINDER

Steering towards a drop in costs: the one cylinder steering axle we have further developed saves money not only on the road but in the fields through reduced fuel consumption and tyre usage. The new combined cylinder also ensures that vehicle manufacturers for example, can operate at maximum efficiency through lower warehousing costs.

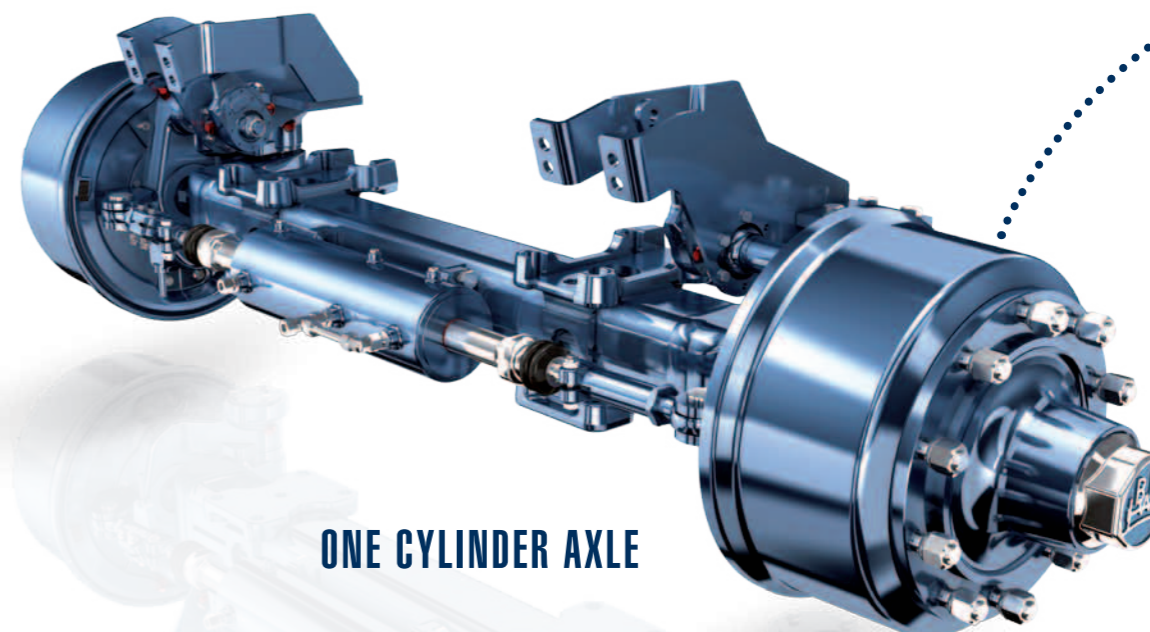

ONE CYLINDER AXLE

Your advantages at a glance:

- Reduced storage through same axle for positive or trailing steering
- No alteration of the axle required when changing between types of steering
- Short decision time for positive or trailing steering possible
- Preparation for TPS (tyre pressure control system) option
- More driving safety: if positive steering fails, the axle can be driven as a trailing steered axle.
- Best possible ground protection when turning corners

HEAVY DUTY

BPW HD BOGIE SUSPENSION

Equipped for the hardest tasks: the new HD bogie suspension impresses with a permissible suspension load of up to 26 tons. The arrangement of the suspensions was effected using the most up to date FEM calculation together with tests carried out in several stages at the testing bench and in field trials. The result is quality which you can rely on, even in the toughest of day to day business.

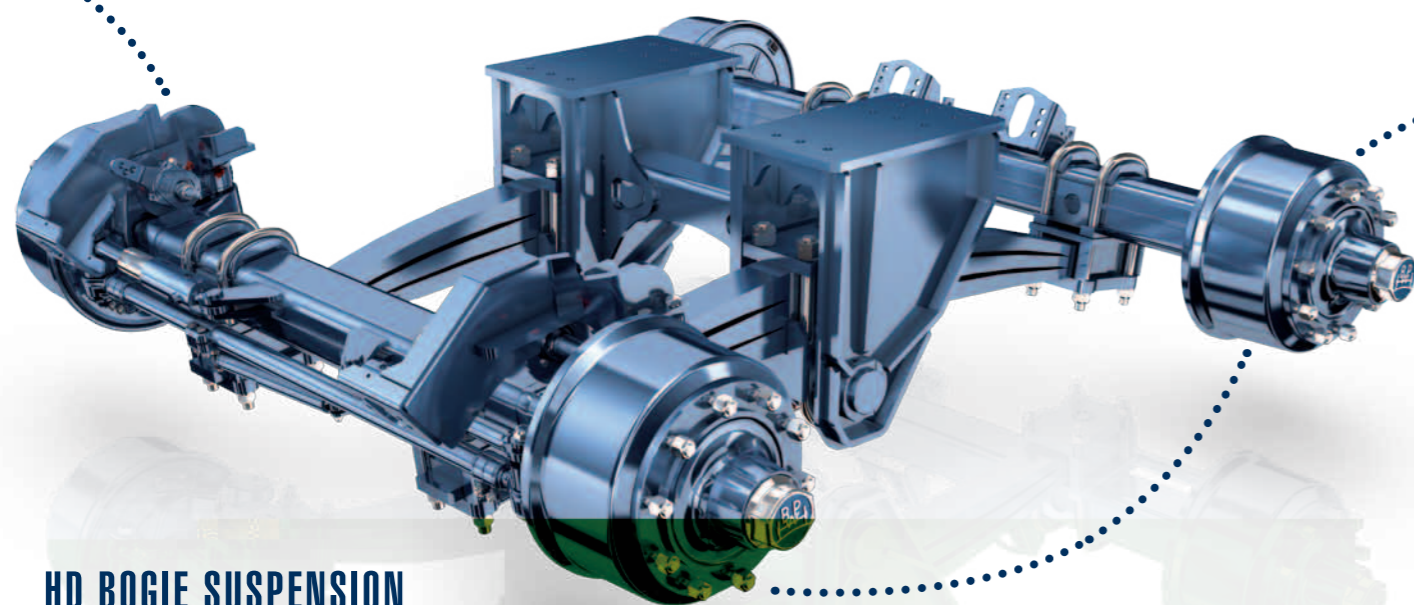

HD BOGIE SUSPENSION

Your advantages at a glance:

- Permissible suspension load of 26 tons – guaranteed through, amongst other things, reinforced springs as well as high-strength steel in the area of the redesigned trunnion block
- Optimally suited for off-road use through large-scale equalization between the axles
- Preparation for TPS (tyre pressure control system) option
- Precise adaptation for use: assembly of the axles above the spring for increased roll stability through a low centre of gravity or assembly of the axles below the spring for increased ground clearance

INTELLIGENT DRIVE

BPW ECO TRONIC EBS

Smarter agricultural running gear: BPW ECO Tronic EBS offers numerous functions which can be used to provide increased driving comfort, safety and economy. The cleverest electronic brake control, however, is no use, if no-one knows how to use it. As a skilled partner organisation, BPW arranges the system so it is geared specifically to meet agricultural needs and provides assistance in implementing and configuring it. This completely ensures that people are not lagging behind technology when it comes to being smart.

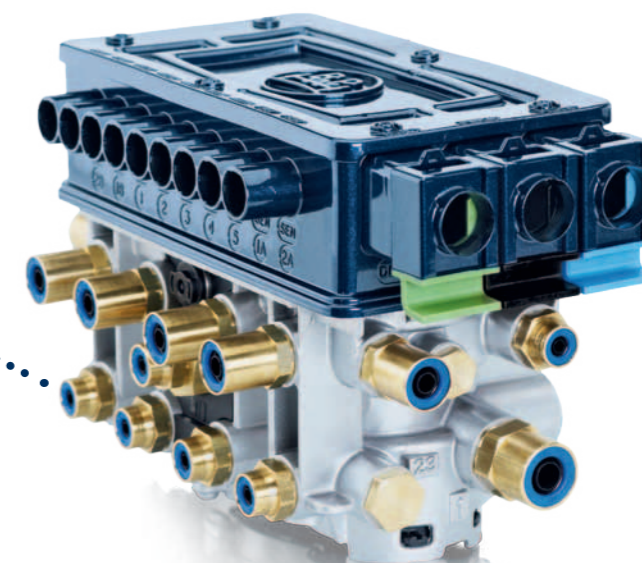

ECO TRONIC EBS

“Thanks to BPW EBS, we do not suffer from damaged turfs any more. The ABS activated by this prevents the wheels from blocking and thus protects the ground surface.”
Patrick Blumberg, Lohnunternehmen Blumberg GmbH & Co. KG

Your advantages at a glance:

- Simplified installation through completely pre-assembled running gears with frames, including brake system and installed ECP Tronic EBS
- More driving safety due to shortened braking distance and increased roll stability
- Reduced tyre wear
- More sensitive brake response
- Ground protection