



BPW Bergische Achsen Kommanditgesellschaft • Postfach 12 80 • D-51656 Wiehl

attention of: **Herrn Köchl**
 E-Mail: KoechlU@bpw.de
 facsimile: **+49 (0) 2262 / 78 - 4137**
 telephone: **+49 (0) 2262 / 78 - 1137**

attention of: **Herrn Abt**
 E-Mail: AbtC@bpw.de
 facsimile: **+49 (0) 2262 / 78 - 4751**
 telephone: **+49 (0) 2262 / 78 - 1751**

from: _____
 company: _____
 street / P. O. B: _____
 postcode, city: _____
 E-Mail: _____
 telephone: _____
 facsimile: _____
 customer no. _____

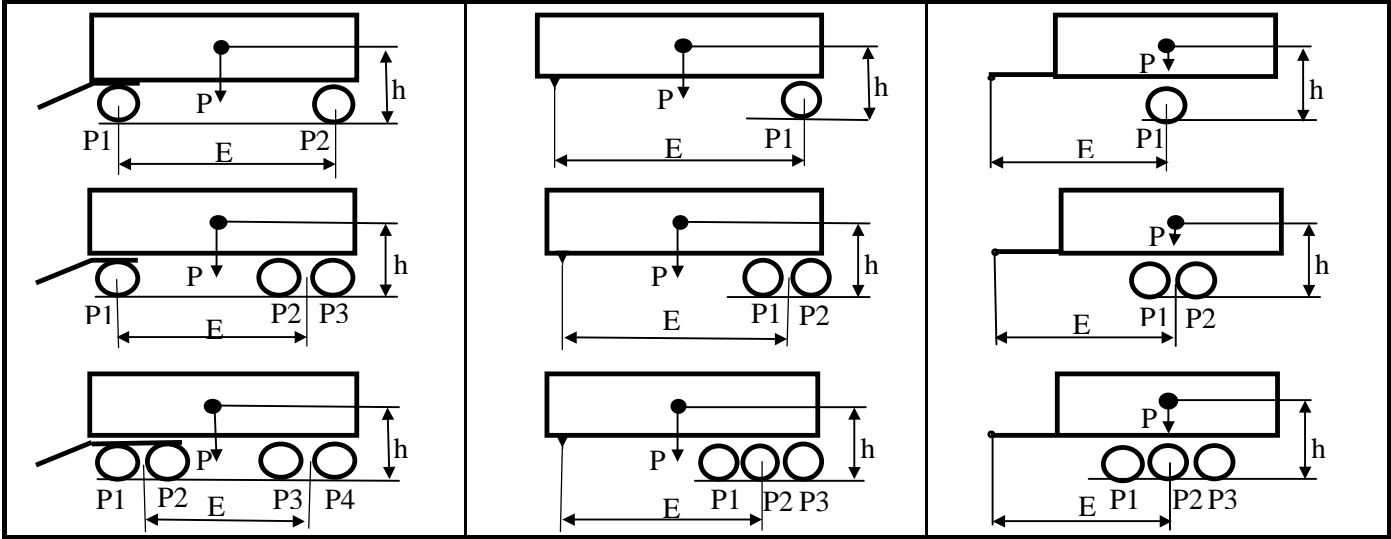

trailer manufacturer			laden	unladen	if already existing	
type of vehicle		gross weight P [kg]			size of brake cylinder	lever length
brake equipment manufacturer		axle load P1 [kg]				
ABS?	Yes No	axle load P2 [kg]				
EBS?	Yes No	axle load P3 [kg]				
brake size		axle load P4 [kg]				
report (TDB) no.		centre of gra- vity h [mm]				
type of axle / code-no.		wheel base E [mm]				
type of suspension / code no.		tyre size 1		eventually tyre size 2		
type of suspension	air	VA VB	W	single axle	hydraulic	

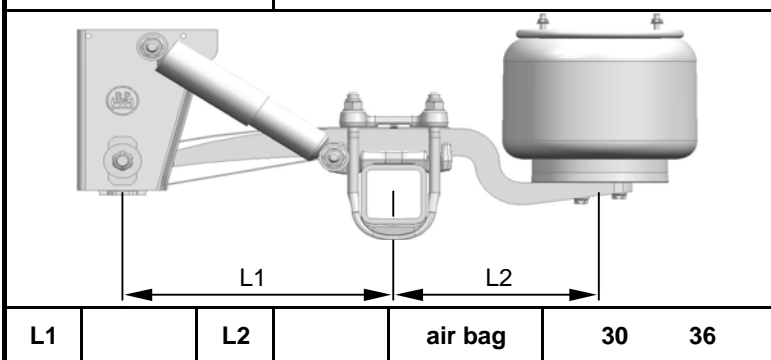

remarks (e. g.: steering axles, lift axles; etc.)

L1 _____ L2 _____ air bag 30 36

Note: Please indicate your customer number.