

## New repair kit for SN 4220

BPW has occupied a leading position in drum brake technology for many years now, and has continuously extended its lead over the competition.

The BPW drum brake sets the standard for towed vehicles because of its robust design and ease of servicing; what is more, upwards of 11 million units have been sold.

Following the successful launch of the ECO Drum generation of brake shoes in the SN 4218, the SN 4220 brake is now being changed over successively.



previously	=>	new
<b>Brake shoe assembly</b>		
05.091.27.82.1	=>	05.091.47.04.1
<b>Repair kit brake</b>		
09.801.02.38.0	=>	09.801.07.49.0
<b>Repair kit in mesh boxes</b>		
99.00.000.6.02	=>	99.00.000.6.23
99.00.000.6.03	=>	99.00.000.6.24

## Repair kit brake shoe assembly with return springs

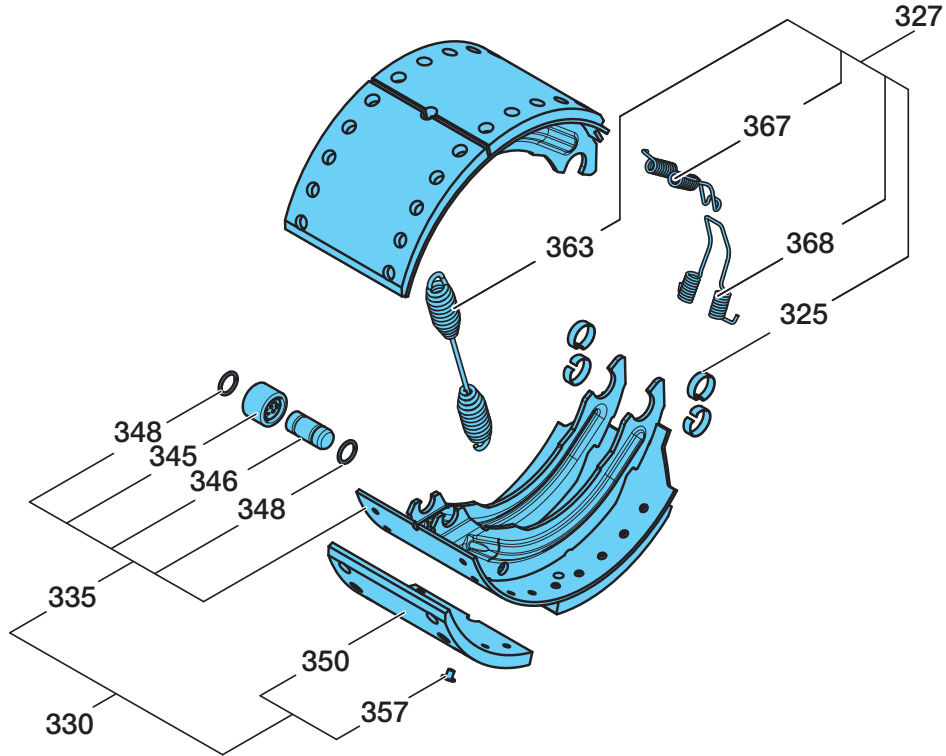

			Repair kit SN 4220	
			previously 09.801.02.38.0	new 09.801.07.49.0
Pos.	Designation	Qty.		
327	Repair kit brake SN 42.. (return springs / ,C' clip)	1	09.801.02.44.0 Pos. 325, 363, 367, 368 incl. Pos. 315, 364 *	09.801.06.79.0 Pos. 325, 363, 367, 368
330	Brake shoe assembly, with lining	4	05.091.27.82.1 Pos. 335, 350, 357	05.091.47.04.1 Pos. 335, 350, 357

**\* ATTENTION!**

Shaped plates (03.167.23.09.0 / no. 315) and return springs (03.397.44.06.0 / no. 364) are no longer included in the new repair kit.  
Please order separately.

Requirement per axle:  
4x 03.167.23.09.0 / no. 315 and 8x 03.397.44.06.0 / no. 364

