

## 9t ECO Plus 2 axle for installation of tyre pressure control systems

With immediate effect, BPW is adding a 9 t ECO Plus 2 axle to its product range that is prepared for the installation of a tyre pressure control system. The axle is available for wheels with ET 0 and ET 120 offset. In preparation for installation of a tyre pressure control system, the axle bolt, axle beam and hub cap have been prepared with access holes and tapped threads where necessary.

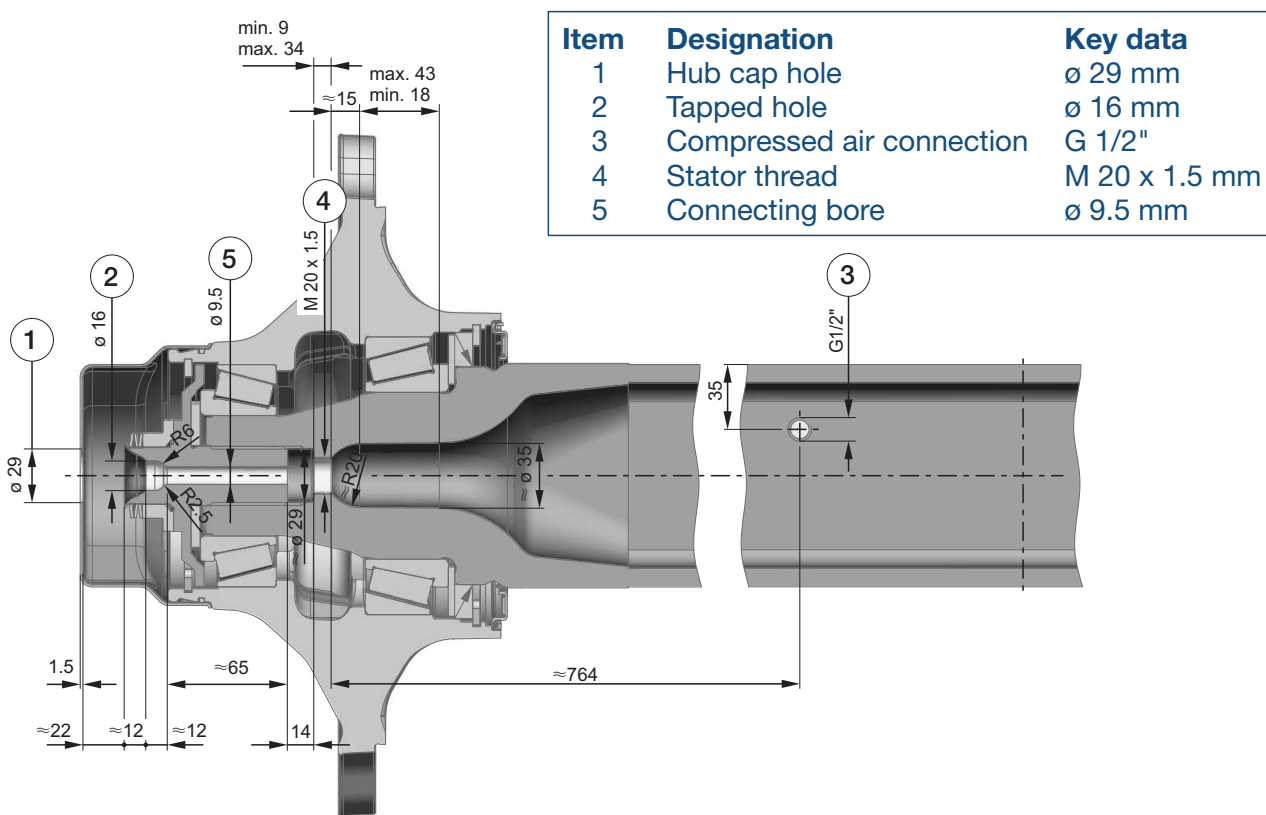

The axle is supplied with a standard hub cap to protect the bearing against moisture. The drilled hub cap intended for installation is also supplied as a separate item.

The positioning of the connections between the axle and the tyre pressure control system must be coordinated directly with the system vendor. The drawing shows the precise dimensions of the access holes and connections.

The BPW warranty for vehicles with a tyre pressure control system only applies if the axle prepared by BPW is used. Subsequent conversion or changes to the connections and access holes on the BPW scope of delivery are not permitted, and will render all warranty claims null and void (warranty). BPW will not accept any liability for damage caused by incorrect mounting or malfunction (i.e. moisture entering through leak).

The axle is available now.

Please do not hesitate to contact BPW sales staff if you have any questions.