

Change of the shock absorber bush

With the introduction of its new ECO Air COMPACT air suspension, BPW is reinforcing the wall strength of the internal steel sleeve of the shock absorber bush.

The inner diameter of the internal steel sleeve as well as the overall diameter of the shock absorber eye remain unchanged. This means the installation ratios and the attachment parts also remain unchanged.

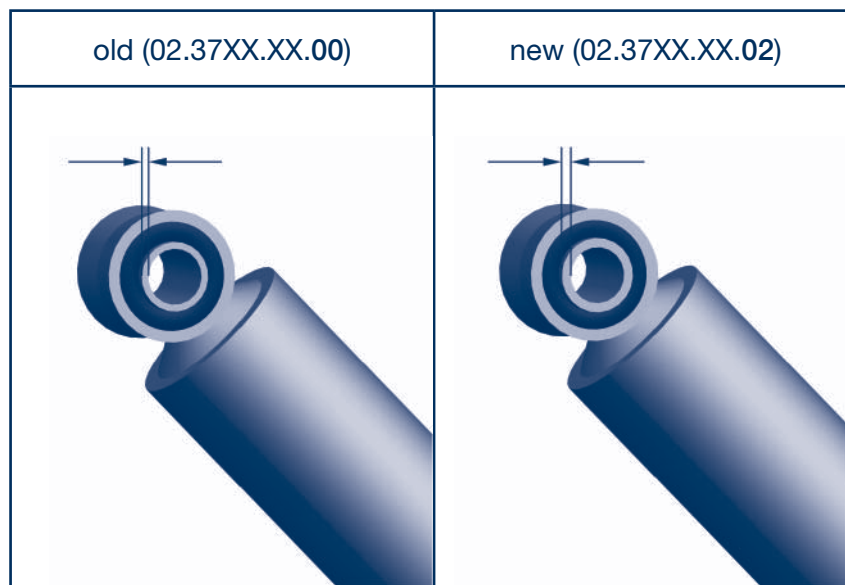

Attaching the shock absorber on the ECO Air COMPACT cast member now requires a higher torque than with the Airlight II designs. This means that reinforcing the bush is required.

The new shock absorber designs are compatible with the old designs and replace these entirely.

The new designs will be progressively used for all air suspensions in BPW original equipment from 1 June 2012 onwards. All the shock absorber designs are affected by this change.

The new shock absorbers can be identified from the changed code number:

Old (02.37XX.XX.00) -->> New (02.37XX.XX.02).

Note: The old designs must not be used in combination with ECO Air COMPACT!