



The brands of the BPW Group:



NEWS Trailer

74532001e

25.11.2020

Market launch of Airlight II with round axle beam 146 x 10 mm

The next milestone on the road to the universal use of the round axle beam at BPW is expected at the beginning of 2021.

Parts of the Airlight II range will be combined with the 146 x 10 mm round axle beam for the first time. In particular, the robust, clamped axle integration using lasered contact surfaces makes it possible to use only the 146 x 10 mm round axle beam in the 9 t on- and offroad sector. The conversion of the reinforced axle beam to the new profile results in significant weight advantages in the offroad-sector.

Versions with the following technical features are affected by the conversion:

- Axle beams 120 x 10 mm and 120 x 15 mm
- 9 t axle load with clamped axle integration
- On- and Offroad use
- Hubs with offset 0 & 120
- 10-hole steel hub
- Single tyres
- Disc brake TS2 4309 and 3709
- Drum brake SN 4218
- Ride height ranges ALO / ALM / ALMT and ALMN
- Leaf springs with the dimensions 1x56 mm & 1x62 mm and LightTube leaf spring

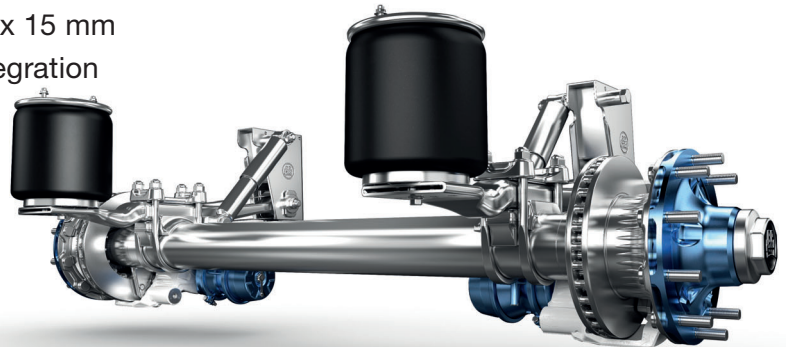

As a BPW customer you benefit from the following advantages:

- Use of one axle version and axle seat for 9 t on- and offroad use
- Especially robust and resistant axle seat due to lasered contact surfaces
- Significant weight advantages by omission of the reinforced axle beam in 9 t offroad use within this product range
- Increased modularity of BPW air suspension ranges - more flexibility for assembly
- “born digital” - availability in the BPW product

It is a 1:1 conversion, the future versions are 100% compatible with the previous versions, the full product range remains unchanged. There are no changes in the interfaces to the vehicle frame, nor do the ride heights change. The use of the LightTube leaf spring and the aluminium hub is possible.

From April 2021, the above-mentioned product range will be delivered exclusively in accordance with the new technical features. If you have any further questions, please contact your BPW contact person.

