

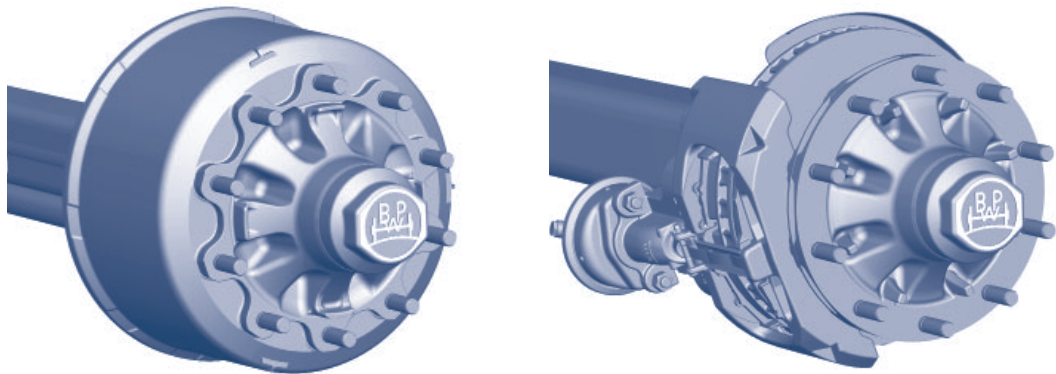

Market launch ECO Plus 3 for 10 - 12 t axles

75142202e
2023-10-27

The series introduction of the ECO Plus 3 bearing technology for axle loads from 10 to 12 t will start in January 2023. The modification of the wheel end versions includes all axle series (NH, KH, SKH, H, SH, L, LL...) and all brake versions.



This provides a globally standardised bearing generation in the axle load range 10 to 12 t: the maintenance-free ECO Plus 3 bearing. It is based on components that have already been installed in 9 t axles since 2015.

The **benefits of ECO Plus bearing system** are:

- Maintenance-free, closed bearing system with 5 + 3-year ECO Plus Warranty with unlimited mileage
- Automatic bearing clearance setting due to the innovative central bolt with integrated torque limitation
- Improved and wear-optimised bearing seal
- Quick maintenance according to the Formula 1 principle via central axle nut
- Worldwide availability of DIN-ISO tapered roller bearings
- Easier spare parts stocking due to same components for 9 to 12 t axle loads (axle nut, taper roller bearing, ECO Plus 3 seal, lock rings)

In this series launch, BPW will fit all axle series with helical fit wheel bolts and will introduce a new, remountable ABS exciter ring. The SKH axles with the TS2 3709 disc brake and reference diameter 8x275 mm will also get a new brake disc in the known IBD design.

The vehicle operator profits from a lower stock of diverse spare parts, faster availability of spare parts and a significantly faster (maintenance) service.

Next steps

Depending on incoming orders and the resulting delivery times, the following steps are planned up to series introduction:

From August 2022

BPW will provide conversion lists of old and new code numbers. Conversion lists can be requested from your BPW contact person.

From September 2022

Existing or new orders with delivery dates after 16 January 2023 can be converted to the new versions. Please coordinate the exact migration date with your BPW contact person.

From January 16, 2023

Launch of the ECO Plus 3 series for 10 to 12 t axles.

Please note the following points:

- Vehicle homologations will not be affected
- The introduction of the ECO Plus 3 will not affect the vehicle interface or BPW's delivery scope. Every existing old design will be replaced by a new design.
- With the start of the launch, axles or modules with old wheel end generations will not be supplied any longer.
- A mixture of the old ECO Plus modules and the new ECO Plus 3 modules within the same vehicle is possible. If you prefer single-variety installation, please revise your inventories and adapt them accordingly.
- It is not possible to return existing stocks to BPW.
- Axles for the aftermarket will be offered only in ECO Plus 3 as of 16.01.2023. Due to the missing compatibility of the individual components, single parts (e.g. hub caps, axle bolts) as well as wheel ends will remain available in the aftermarket.

Your BPW contact person can provide you with further information.