



Weight-optimized BPW stub axles for inloaders with aluminium wheels

75532401e
2024-02-01

The 10 t MVBF stub axles are mainly used in inloaders. In addition to the very limited installation space, the payload is also an important issue here.

BPW has developed a weight-optimized brake drum for perfect combination with aluminium wheels. After more than 2 years of field testing, the new lightweight drum (03.109.67.96.0) was successfully qualified and introduced into series production.

By optimizing the standard brake drum for the ECO DRUM SN 4218, BPW was able to realize a weight reduction of approx. 3 kg. This means a weight advantage of around 6 kg per axle line.

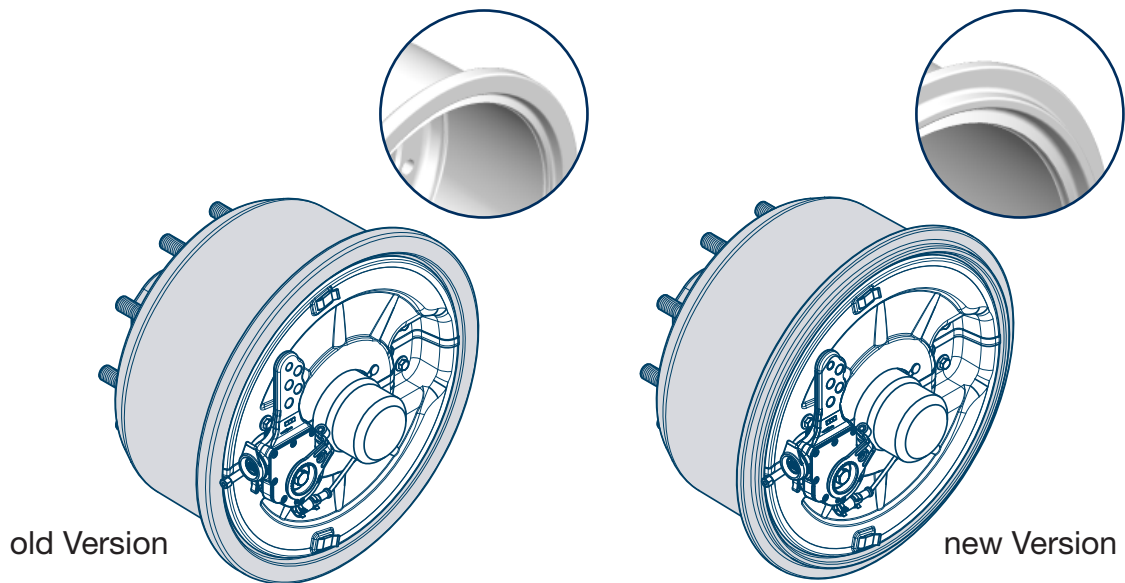

The further features of the ECO DRUM, such as quick and easy brake service thanks to the ECO principle and the particularly high-quality sealing of the brake camshaft bearing, are unchanged. With the series introduction of ECO Plus 3 bearing technology in 2023, BPW stub axles will also have an improved and wear-optimized wheel bearing seal and a new, remountable ABS exciter ring.

If a service is required, the previous brake drums can be replaced with the new brake drum 03.109.67.96.0. The brake drums must be replaced for each axle line.

You can also request detailed information from your BPW contact person.