

we think transport



PERFECT COATING.

BPW cathodic dip coating (KTL + Zn)

COMPREHENSIVE PROTECTION FOR ALL COMPONENTS.

Our running gear are known for being durable and robust. One key to this is the KTL + Zn cathodic dip coating. This cathodic dip coating with zinc phosphating is significantly more corrosion-resistant than conventional priming with a topcoat and reliably prevents rust forming beneath the surface. The special surface finish covers even hard-to-reach areas, provides five times more corrosion protection than conventional painting processes and withstands even the hardest stone impacts and harshest cleaning chemicals. The KTL + Zn coating complies with salt-spray testing in accordance with DIN EN ISO 9227 at 504 hours and withstands the hardest stone impacts and harshest cleaning chemicals.

01

COMPREHENSIVE CORROSION PROTECTION

Even in inaccessible areas

02

MINIMUM CORROSION CREEP

For instance if the surface is damaged by stone impact or grit

03

HIGH CHEMICAL RESISTANCE

For example when using pressure washers with detergent additives

04

OUTSTANDING APPEARANCE

Surfaces have even coat thickness with no drips or runs

05

SIMPLE TOPCOAT APPLICATION

If there are individual requirements in terms of gloss level and colour, topcoats can be applied with cost-effective topcoat systems with no need for pretreatment

06

ENVIRONMENTALLY FRIENDLY COATING PROCESS

No environmentally harmful substances are released

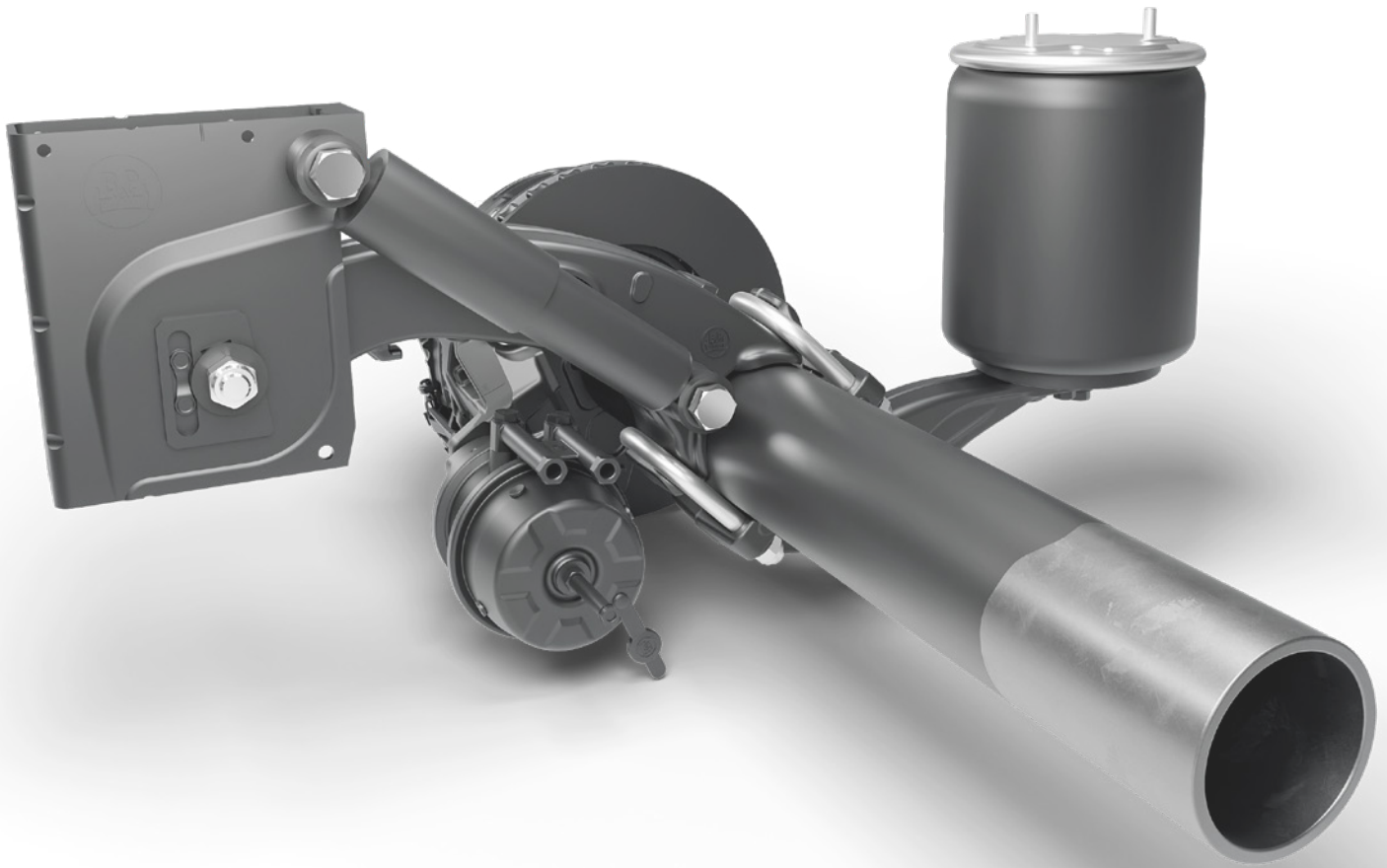

PREVENTS DAMAGE DURING TRANSPORT AND ASSEMBLY



REDUCTION IN DOWNTIME



REDUCTION IN MAINTENANCE AND REPAIR WORK



HIGH HEAT RESISTANCE

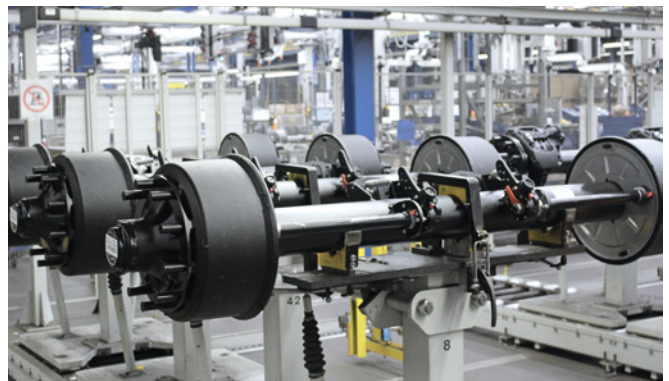

BPW coats all running gear itself at its own plants.

The brands of the BPW Group:



BPW KTL Coating 19312101 e reaze GmbH

BPW Bergische Achsen Kommanditgesellschaft

Postbox 12 80 · 51656 Wiehl, Germany · Telephone +49 2262 78-0
info@bpw.de · www.bpw.de