

**THE NETHERLANDS  
(N E D E R L A N D)****ECE R13-11, Annex 11 – Appendix 3  
Test report as prescribed in Paragraphs 3.9. of Appendix 2 to this Annex****Test report number: RDW 19160120****Extension number: 02**

Base part: ID4- 19160120

Suffix: 02

1. General
  - 1.1. Axle manufacturer (name and address) : BPW Bergische Achsen Kommanditgesellschaft.  
D-51674 Wiehl
    - 1.1.1. Make of axle manufacturer : BPW
  - 1.2. Brake manufacturer (name and address) : See 1.1.
    - 1.2.1. Brake identifier : ID2-SN4220
    - 1.2.2. Automatic brake adjustment device : ~~integrated~~/non-integrated<sup>(1)</sup>
  - 1.3. Manufacturer's Information Document : See item 6.



## A.2. Test Record

The following data has to be recorded for each test:

- A.2.1. Test code (see paragraph 3.9.2. of Appendix 2 of this annex) : A2.x :AA 151117
- A.2.2. Test specimen: (precise identification of the variant tested related to the Manufacturer's Information Document. See also paragraph 3.9.2. of Appendix 2 of this annex)  
...
- A.2.2.1. Axle
- A.2.2.1.1. Axle identifier : ID1-H122
- A.2.2.1.2. Identification of tested axle : 27.50.744.102
- A.2.2.1.3. Test axle load ( $F_e$  identifier) : ID3-11968
- A.2.2.2. Brake
- A.2.2.2.1. Brake identifier : ID2-SN4220
- A.2.2.2.2. Identification of tested brake : 03.109.77.42.0.
- A.2.2.2.3. Maximum stroke capability of the brake<sup>(2)</sup> : -
- A.2.2.2.4. Effective length of the cam shaft<sup>(3)</sup> : 286 (mm).
- A.2.2.2.5. Material variation as per paragraph 3.8 (m) of Appendix 2 of this annex : N.A.
- A.2.2.2.6. Brake drum/disc<sup>(1)</sup>
- A.2.2.2.6.1. Actual test mass of disc/drum<sup>(1)</sup> : 48 kg
- A.2.2.2.6.2. Nominal external diameter of disc<sup>(2)</sup> : N.A.
- A.2.2.2.6.3. Type of cooling of the disc ventilated/non-ventilated<sup>(1)</sup> : N.A.
- A.2.2.2.6.4. With or without integrated hub<sup>(1)</sup> : N.A.
- A.2.2.2.6.5. Disc with integrated drum - with or without parking brake function<sup>(1)(2)</sup> : N.A.
- A.2.2.2.6.6. Geometric relationship between disc friction surfaces and disc mounting : N.A.
- A.2.2.2.6.7. Base material : Grey Cast Iron



- A.2.2.2.7. Brake lining or pad <sup>(1)</sup>
- A.2.2.2.7.1. Manufacturer : TMD Friction , Leverkusen.
- A.2.2.2.7.2. Make : Textar
- A.2.2.2.7.3. Type : T090
- A.2.2.2.7.4. Method of attachment of the lining/pad on the brake shoe/~~back plate~~ <sup>(1)</sup> : Riveted.
- A.2.2.2.7.5. Thickness of back plate, weight of shoes or other describing information (Manufacturer's Information Document) <sup>(1)</sup> : See information document.
- A.2.2.2.7.6. Base material of brake shoe/back plate <sup>(1)</sup> : Steel.
- A.2.2.3. Automatic brake adjustment device (not applicable in the case of integrated automatic brake adjustment device) <sup>(1)</sup>
- A.2.2.3.1. Manufacturer (name and address) : See 1.1.
- A.2.2.3.2. Make : BPW
- A.2.2.3.3. Type : AGS
- A.2.2.3.4. Version : 0
- A.2.2.4. Wheel(s) (dimensions see Figures 1A and 1B in Appendix 5 of this annex)
- A.2.2.4.1. Reference tyre rolling radius ( $R_e$ ) at test axle load ( $F_e$ ) : 522 (mm)
- A.2.2.4.2. Data of the fitted wheel during testing:
- | Tyre size   | Rim size    | $X_e$ (mm) | $D_e$ (mm) | $E_e$ (mm) | $G_e$ (mm) |
|-------------|-------------|------------|------------|------------|------------|
| 315/80R22,5 | 22,5 x 8.00 | 259,5      | 571,5      | 21,5       | - 45       |
- A.2.2.5. Lever length  $l_e$  : 165 (mm)
- A.2.2.6. Brake actuator
- A.2.2.6.1. Manufacturer : BPW Bergische Achsen
- A.2.2.6.2. Make : BPW
- A.2.2.6.3. Type : 05.444.16(30")
- A.2.2.6.4. (Test) identification number : BC 0069.2



A.2.3. Test results (corrected to take account of rolling resistance of 0.01 -  $F_e$ )

A.2.3.2. In the case of vehicles of categories O<sub>4</sub>

Test type:		0	III	
Annex 11, Appendix 2, paragraph:		3.5.1.2.	3.5.3.1.	3.5.3.2.
Test speed initial	km/h	60	60	60
Test speed final	km/h	0	30	0
Brake actuator pressure $p_e$	kPa	650	-	650
Number of brake applications	-	-	20	-
Duration of braking cycle	s	-	60	-
Brake force developed $T_e$	N	64433	36046	58049
Brake efficiency $T_e/F_e$	-	0,54	0,30	0,49
Actuator stroke $S_e$	mm	36,8	-	48,6
Brake input torque $C_e$	Nm	2034	-	2034
Brake input threshold torque $C_{o,e}$	Nm	50	-	50



## B.2. Test Record

The following data has to be recorded for each test:

- B.2.1. Test code (see paragraph 3.9.2. of Appendix 2 of this annex) : B2.x:AA 151117
- B.2.2. Test specimen: (precise identification of the variant tested related to the Manufacturer's Information Document. See also paragraph 3.9.2. of Appendix 2 of this annex)  
...
- B.2.2.1. Axle
- B.2.2.1.1. Axle identifier : ID1-H122
- B.2.2.1.2. Identification of tested axle : 27.50.744.102
- B.2.2.1.3. Test axle load ( $F_e$  identifier) : ID3-11968
- B.2.2.2. Brake
- B.2.2.2.1. Brake identifier : ID2-SN4220
- B.2.2.2.2. Identification of tested brake : 03.109.77.42.0.
- B.2.2.2.3. Maximum stroke capability of the brake<sup>(2)</sup> : -
- B.2.2.2.4. Effective length of the cam shaft<sup>(3)</sup> : 706 (mm).
- B.2.2.2.5. Material variation as per paragraph 3.8 (m) of Appendix 2 of this annex : N.A.
- B.2.2.2.6. Brake drum/disc<sup>(1)</sup>
- B.2.2.2.6.1. Actual test mass of disc/drum<sup>(1)</sup> : 48 kg
- B.2.2.2.6.2. Nominal external diameter of disc<sup>(2)</sup> : N.A.
- B.2.2.2.6.3. Type of cooling of the disc ventilated/non-ventilated<sup>(1)</sup> : N.A.
- B.2.2.2.6.4. With or without integrated hub<sup>(1)</sup> : N.A.
- B.2.2.2.6.5. Disc with integrated drum - with or without parking brake function<sup>(1)(2)</sup> : N.A.
- B.2.2.2.6.6. Geometric relationship between disc friction surfaces and disc mounting : N.A.
- B.2.2.2.6.7. Base material : Grey Cast Iron



B.2.2.2.7. Brake lining or pad <sup>(1)</sup>

B.2.2.2.7.1. Manufacturer : TMD Friction , Leverkusen.

B.2.2.2.7.2. Make : Textar

B.2.2.2.7.3. Type : T090

B.2.2.2.7.4. Method of attachment of the lining/pad  
on the brake shoe/~~back plate~~ <sup>(1)</sup> : Riveted.B.2.2.2.7.5. Thickness of back plate, weight of  
shoes or other describing information  
(Manufacturer's Information  
Document) <sup>(1)</sup> : See information document.B.2.2.2.7.6. Base material of brake shoe/back plate <sup>(1)</sup> : Steel.B.2.2.3. Automatic brake adjustment device (not applicable in the case of integrated automatic brake  
adjustment device) <sup>(1)</sup>

B.2.2.3.1. Manufacturer (name and address) : See 1.1.

B.2.2.3.2. Make : BPW

B.2.2.3.3. Type : AGS

B.2.2.3.4. Version : 2

## B.2.2.4. Wheel(s) (dimensions see Figures 1A and 1B in Appendix 5 of this annex)

B.2.2.4.1. Reference tyre rolling radius ( $R_e$ ) at test  
axle load ( $F_e$ ) : 522 (mm)

B.2.2.4.2. Data of the fitted wheel during testing:

Tyre size	Rim size	$X_e$ (mm)	$D_e$ (mm)	$E_e$ (mm)	$G_e$ (mm)
315/80R22,5	22,5 x 8.00	259,5	571,5	21,5	-45

B.2.2.5. Lever length  $l_e$  : 165 (mm)

## B.2.2.6. Brake actuator

B.2.2.6.1. Manufacturer : BPW Bergische Achsen

B.2.2.6.2. Make : BPW

B.2.2.6.3. Type : 05.444.16(30")

B.2.2.6.4. (Test) identification number : BC 0069.2

B.2.3. Test results (corrected to take account of rolling resistance of 0.01 -  $F_e$ )

B.2.3.2. In the case of vehicles of categories O<sub>4</sub>

Test type:		0	III	
Annex 11, Appendix 2, paragraph:		3.5.1.2.	3.5.3.1.	3.5.3.2.
Test speed initial	km/h	60	60	60
Test speed final	km/h	0	30	0
Brake actuator pressure $p_e$	kPa	636	-	636
Number of brake applications	-	-	20	-
Duration of braking cycle	s	-	60	-
Brake force developed $T_e$	N	71143	35889	61465
Brake efficiency $T_e/F_e$	-	0,59	0,30	0,51
Actuator stroke $S_e$	mm	44,6	-	60,4
Brake input torque $C_e$	Nm	1983	-	1983
Brake input threshold torque $C_{o,e}$	Nm	50	-	50



## C.2. Test Record

The following data has to be recorded for each test:

- C.2.1. Test code (see paragraph 3.9.2. of Appendix 2 of this annex) : C2.x :AA 271117
- C.2.2. Test specimen: (precise identification of the variant tested related to the Manufacturer's Information Document. See also paragraph 3.9.2. of Appendix 2 of this annex)  
...
- C.2.2.1. Axle
- C.2.2.1.1. Axle identifier : ID1-H122
- C.2.2.1.2. Identification of tested axle : 25.50.744.102
- C.2.2.1.3. Test axle load ( $F_e$  identifier) : ID3-11968
- C.2.2.2. Brake
- C.2.2.2.1. Brake identifier : ID2-SN4220
- C.2.2.2.2. Identification of tested brake : 03.109.77.42.0.
- C.2.2.2.3. Maximum stroke capability of the brake<sup>(2)</sup> : -
- C.2.2.2.4. Effective length of the cam shaft<sup>(3)</sup> : 286 (mm).
- C.2.2.2.5. Material variation as per paragraph 3.8 (m) of Appendix 2 of this annex : N.A.
- C.2.2.2.6. Brake drum/disc<sup>(1)</sup>
- C.2.2.2.6.1. Actual test mass of disc/drum<sup>(1)</sup> : 48 kg
- C.2.2.2.6.2. Nominal external diameter of disc<sup>(2)</sup> : N.A.
- C.2.2.2.6.3. Type of cooling of the disc ventilated/non-ventilated<sup>(1)</sup> : N.A.
- C.2.2.2.6.4. With or without integrated hub<sup>(1)</sup> : N.A.
- C.2.2.2.6.5. Disc with integrated drum - with or without parking brake function<sup>(1)(2)</sup> : N.A.
- B.2.2.2.6.6. Geometric relationship between disc friction surfaces and disc mounting : N.A.
- C.2.2.2.6.7. Base material : Grey Cast Iron





C.2.2.2.7. Brake lining or pad <sup>(1)</sup>C.2.2.2.7.1. Manufacturer : Bremskerl, Estorf-Leeseringen

C.2.2.2.7.2. Make : BPW

C.2.2.2.7.3. Type : 6502C.2.2.2.7.4. Method of attachment of the lining/~~pad~~  
on the brake shoe/~~back plate~~ <sup>(1)</sup> : Riveted.C.2.2.2.7.5. Thickness of back plate, weight of  
shoes or other describing information  
(Manufacturer's Information  
Document) <sup>(1)</sup> : See information document.C.2.2.2.7.6. Base material of brake shoe/back plate <sup>(1)</sup> : Steel.C.2.2.3. Automatic brake adjustment device (not applicable in the case of integrated automatic brake  
adjustment device) <sup>(1)</sup>

C.2.2.3.1. Manufacturer (name and address) : See 1.1.

C.2.2.3.2. Make : BPW

C.2.2.3.3. Type : AGS

C.2.2.3.4. Version : 0

## C.2.2.4. Wheel(s) (dimensions see Figures 1A and 1B in Appendix 5 of this annex)

C.2.2.4.1. Reference tyre rolling radius ( $R_e$ ) at test  
axle load ( $F_e$ ) : 522 (mm)

## C.2.2.4.2. Data of the fitted wheel during testing:

Tyre size	Rim size	$X_e$ (mm)	$D_e$ (mm)	$E_e$ (mm)	$G_e$ (mm)
315/80R22,5	22,5 x 8.00	259,5	571,5	21,5	-45

C.2.2.5. Lever length  $l_e$  : 165 (mm)

## C.2.2.6. Brake actuator

C.2.2.6.1. Manufacturer : BPW Bergische Achsen

C.2.2.6.2. Make : BPW

C.2.2.6.3. Type : 05.444.16(30")

C.2.2.6.4. (Test) identification number : BC 0069.2

C.2.3. Test results (corrected to take account of rolling resistance of 0.01 -  $F_e$ )

C.2.3.2. In the case of vehicles of categories O<sub>4</sub>

Test type:		0	III	
Annex 11, Appendix 2, paragraph:		3.5.1.2.	3.5.3.1.	3.5.3.2.
Test speed initial	km/h	60	60	60
Test speed final	km/h	0	30	0
Brake actuator pressure $p_e$	kPa	636	-	636
Number of brake applications	-	-	20	-
Duration of braking cycle	s	-	60	-
Brake force developed $T_e$	N	65979	35804	58171
Brake efficiency $T_e/F_e$	-	0,55	0,29	0,49
Actuator stroke $S_e$	mm	35,5	-	49,8
Brake input torque $C_e$	Nm	1983	-	1983
Brake input threshold torque $C_{o,e}$	Nm	50	-	50



## D.2. Test Record

The following data has to be recorded for each test:

- D.2.1. Test code (see paragraph 3.9.2. of Appendix 2 of this annex) : D2.x :AA 281117
- D.2.2. Test specimen: (precise identification of the variant tested related to the Manufacturer's Information Document. See also paragraph 3.9.2. of Appendix 2 of this annex)  
...
- D.2.2.1. Axle
- D.2.2.1.1. Axle identifier : ID1-H122
- D.2.2.1.2. Identification of tested axle : 25.50.744.102
- D.2.2.1.3. Test axle load ( $F_e$  identifier) : ID3-11968
- D.2.2.2. Brake
- D.2.2.2.1. Brake identifier : ID2-SN4220
- D.2.2.2.2. Identification of tested brake : 03.109.77.42.0.
- D.2.2.2.3. Maximum stroke capability of the brake<sup>(2)</sup> : -
- D.2.2.2.4. Effective length of the cam shaft<sup>(3)</sup> : 706 (mm).
- D.2.2.2.5. Material variation as per paragraph 3.8 (m) of Appendix 2 of this annex : N.A.
- D.2.2.2.6. Brake drum/disc<sup>(1)</sup>
- D.2.2.2.6.1. Actual test mass of disc/drum<sup>(1)</sup> : 48 kg
- D.2.2.2.6.2. Nominal external diameter of disc<sup>(2)</sup> : N.A.
- D.2.2.2.6.3. Type of cooling of the disc ventilated/non-ventilated<sup>(1)</sup> : N.A.
- D.2.2.2.6.4. With or without integrated hub<sup>(1)</sup> : N.A.
- D.2.2.2.6.5. Disc with integrated drum - with or without parking brake function<sup>(1)(2)</sup> : N.A.
- D.2.2.2.6.6. Geometric relationship between disc friction surfaces and disc mounting : N.A.
- D.2.2.2.6.7. Base material : Grey Cast Iron



D.2.2.2.7. Brake lining or pad <sup>(1)</sup>

D.2.2.2.7.1. Manufacturer : Bremskerl, Estorf-Leeseringen

D.2.2.2.7.2. Make : BPW

D.2.2.2.7.3. Type : 6502

D.2.2.2.7.4. Method of attachment of the lining/~~pad~~  
on the brake shoe/~~back plate~~ <sup>(1)</sup> : Riveted.

D.2.2.2.7.5. Thickness of back plate, weight of shoes or other describing information (Manufacturer's Information Document) <sup>(1)</sup> : See information document.

D.2.2.2.7.6. Base material of brake shoe/back plate <sup>(1)</sup> : Steel.

D.2.2.3. Automatic brake adjustment device (not applicable in the case of integrated automatic brake adjustment device) <sup>(1)</sup>

D.2.2.3.1. Manufacturer (name and address) : See 1.1.

D.2.2.3.2. Make : BPW

D.2.2.3.3. Type : AGS

D.2.2.3.4. Version : 2

D.2.2.4. Wheel(s) (dimensions see Figures 1A and 1B in Appendix 5 of this annex)

D.2.2.4.1. Reference tyre rolling radius ( $R_e$ ) at test axle load ( $F_e$ ) : 522 (mm)

D.2.2.4.2. Data of the fitted wheel during testing:

Tyre size	Rim size	$X_e$ (mm)	$D_e$ (mm)	$E_e$ (mm)	$G_e$ (mm)
315/80R22,5	22,5 x 8.00	259,5	571,5	21,5	-45

D.2.2.5. Lever length  $l_e$  : 165 (mm)

D.2.2.6. Brake actuator

D.2.2.6.1. Manufacturer : BPW Bergische Achsen

D.2.2.6.2. Make : BPW

D.2.2.6.3. Type : 05.444.16(30")

D.2.2.6.4. (Test) identification number : BC 0069.2



D.2.3. Test results (corrected to take account of rolling resistance of 0.01 -  $F_e$ )

D.2.3.2. In the case of vehicles of categories O<sub>4</sub>

Test type:		0	III	
Annex 11, Appendix 2, paragraph:		3.5.1.2.	3.5.3.1.	3.5.3.2.
Test speed initial	km/h	60	60	60
Test speed final	km/h	0	30	0
Brake actuator pressure $p_e$	kPa	595	-	595
Number of brake applications	-	-	20	-
Duration of braking cycle	s	-	60	-
Brake force developed $T_e$	N	69354	37752	59391
Brake efficiency $T_e/F_e$	-	0,58	0,31	0,50
Actuator stroke $S_e$	mm	45,0	-	58,8
Brake input torque $C_e$	Nm	1850	-	1850
Brake input threshold torque $C_{o,e}$	Nm	50	-	50

2.3.3. This item is to be completed only when the brake has been subject to the test procedure defined in paragraph 4. of Annex 19 to this Regulation to verify the cold performance characteristics of the brake by means of the brake factor ( $B_F$ ).

2.3.3.1. Brake factor ( $B_F$ ) : 9

2.3.3.2. Declared threshold torque  $C_{0,dec}$  : 50 Nm

2.3.4. Performance of the automatic adjustment device (if applicable)

2.3.4.1. Free running according to paragraph 3.6.3. of Annex 11, Appendix 2 : yes/~~no~~<sup>(1)</sup>

3. Application range

This application range specifies the axle/brake variants that are covered in this test report, by showing which variables are covered by the individual test codes.

4. This test has been carried out and the results reported in accordance with Appendix 2 to Annex 11 and where appropriate paragraph 4. of Annex 19 to Regulation number 13 as last amended by the 10 series of amendments.

At the end of the test defined in paragraph 3.6. of Annex 11, Appendix 2<sup>(4)</sup> the requirements of paragraph 5.2.2.8.1. of Regulation number 13 were deemed to be fulfilled/~~not fulfilled~~<sup>(1)</sup>



Technical Service <sup>(5)</sup> carrying out the test RDW  
Europaweg 205  
P.O. Box 777  
2700 AT Zoetermeer  
The Netherlands

Signed :

The image shows a blue ink signature of W.R. Hartman written over a circular stamp. The stamp features the RDW logo, which includes a crown and a shield with two lions, and the text 'RDW' below it.

W.R. Hartman

Date : 31 January 2018

Approval authority <sup>(5)</sup> RDW  
Europaweg 205  
P.O. Box 777  
2700 AT Zoetermeer  
The Netherlands

Signed :

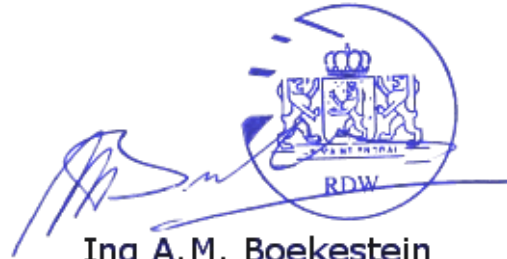
The image shows a blue ink signature of Ing A.M. Boekestein written over a circular stamp. The stamp features the RDW logo, which includes a crown and a shield with two lions, and the text 'RDW' below it.

Ing A.M. Boekestein

Date : 31 January 2018

---

<sup>(1)</sup> Strike out what does not apply.

<sup>(2)</sup> Applies to disc brakes only.

<sup>(3)</sup> Applies to drum brakes only.

<sup>(2)</sup> Applies to disc brakes only.

<sup>(3)</sup> Applies to drum brakes only.

<sup>(2)</sup> Applies to disc brakes only.

<sup>(3)</sup> Applies to drum brakes only.

<sup>(2)</sup> Applies to disc brakes only.

<sup>(3)</sup> Applies to drum brakes only.

<sup>(4)</sup> Only to be completed when an automatic brake wear adjustment device is installed.

<sup>(5)</sup> To be signed by different persons even when the Technical Service and Approval Authority are the same or alternatively, a separate approval Authority authorization is issued with the report.

# Information Document BPW -SN4220.00

## TRAILER AXLE AND BRAKE INFORMATION DOCUMENT WITH RESPECT TO THE ALTERNATIVE TYPE I AND TYPE III PROCEDURE

(according to ECE R 13, Annex 11 – Appendix 5)

Date	Revision	Position	Amendment of terms
05.02.2014	01		
15.11.2017	02	2.4	New test axle load (was $F_e = 11772$ daN)

### 1. GENERAL

#### 1.1. Name and address of axle or vehicle manufacturer:

BPW Bergische Achsen KG  
Ohlerhammer  
D-51674 Wiehl

### 2. AXLE DATA

- 2.1. Manufacturer (name and address) ..... see 1.1.  
 2.2. Type/variant ..... H  
 2.3. Axle identifier ID1- ..... H 122  
 2.4. Test axle load ( $F_e$ ) ID3- ..... 11968 daN  
 2.5. Wheel and brake data according to the following figure 1A:

FIGURE 1A

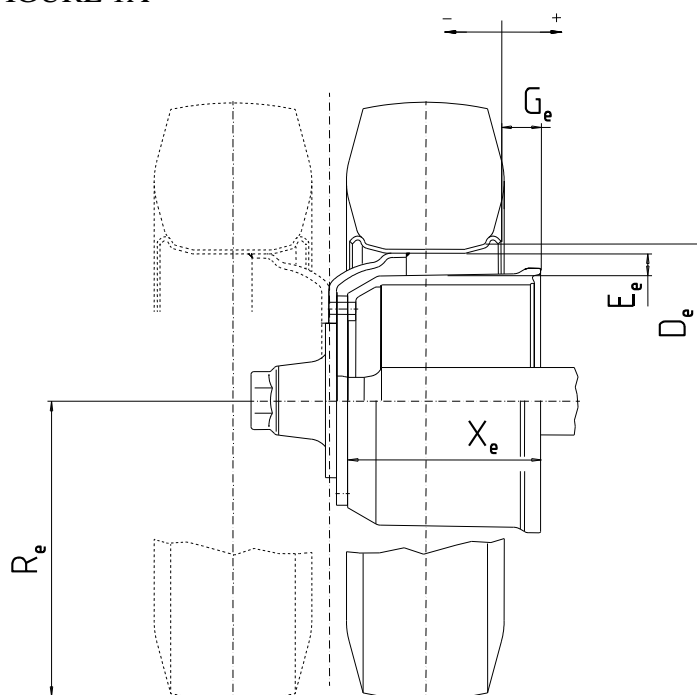

Permitted range:

D (mm)	E (mm)	G (mm)	R (mm)	X (mm)
min. 571,5	min. 21,5	min. -45	min. 0,8 * 522	min. 259

3. BRAKE
- 3.1. General information
- 3.1.1. Make .....BPW
- 3.1.2. Manufacturer (name and address) ..... see 1.1.
- 3.1.3. Type of brake (e.g. drum / disc) .....Drum Brake
- 3.1.3.1. Variant (e.g. S-cam, single wedge etc.) ..... S-cam brake
- 3.1.4. Brake identifier ID2- ..... SN 4220
- 3.1.5. Brake data according to the following figure 2A:

FIGURE 2A

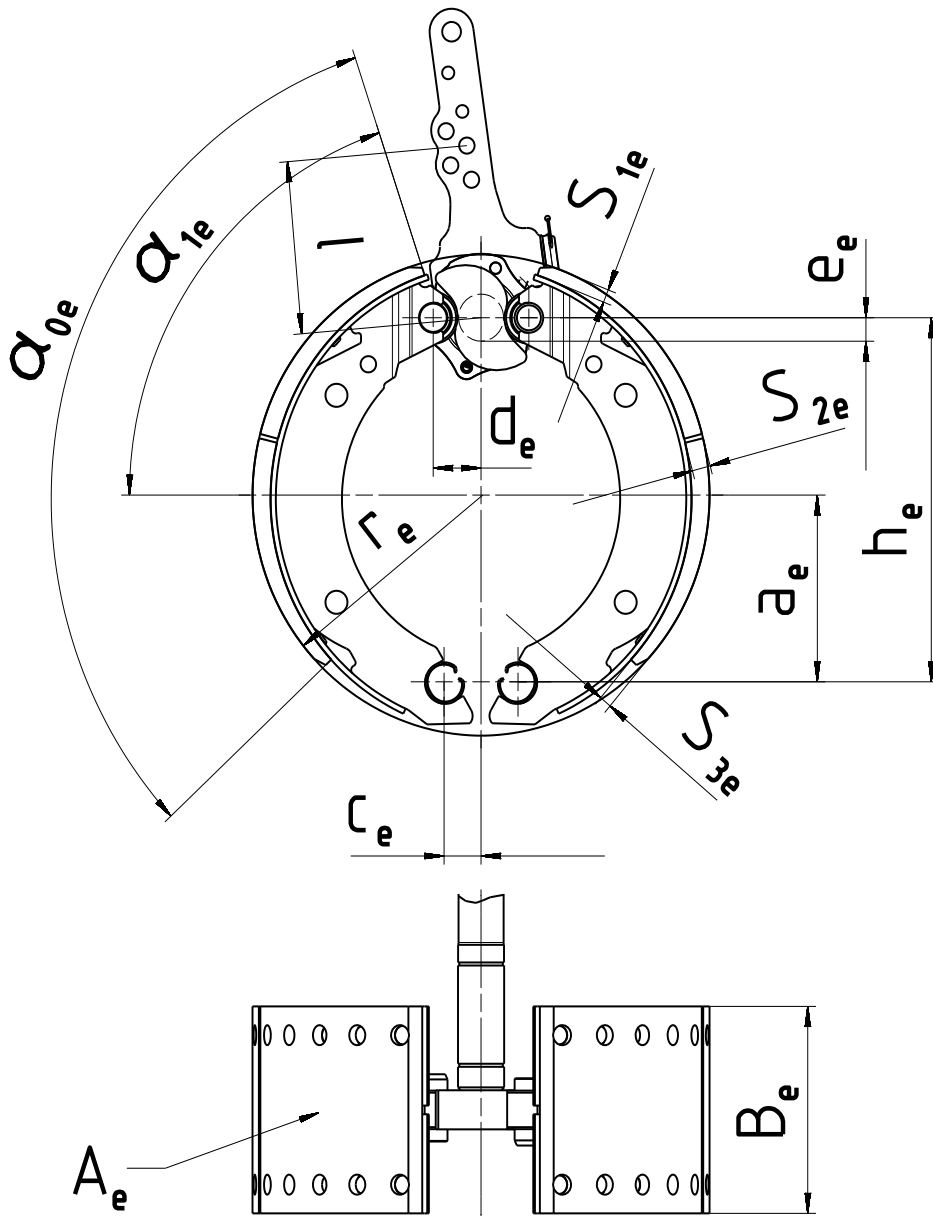

$a_e$ (mm)	$h_e$ (mm)	$c_e$ (mm)	$d_e$ (mm)	$e_e$ (mm)	$\alpha_{0e}$ (°)	$\alpha_{1e}$ (°)	$B_e$ (mm)	$r_e$ (mm)	$A_e$ (cm <sup>2</sup> )	$S_{1e}$ (mm)	$S_{2e}$ (mm)	$S_{3e}$ (mm)
163,7	317,7	33	43,5	14	114	70,5	200	210	1554	13	18	13

3.1.6. Brake factor  $B_F$  ..... 9,0



3.2. Drum brake data

3.2.1. Brake adjustment device (external/integrated) .....external

3.2.1.1.	3.2.1.2.	3.2.1.3.	3.2.1.4.	3.2.1.5.	3.2.1.6.	3.2.1.7.	3.2.1.8.
Alternative	Manufacturer and address	Make	Type	Version	Effective length of the cam shaft	Brake lining	Test code
A	see 1.1.	BPW	AGS-	0	max.286 mm	Textar T090	AA151117
B	see 1.1.	BPW	AGS-	2	max.706 mm	Textar T090	AA151117
A	see 1.1.	BPW	AGS-	0	max. 286 mm	BPW 6502	AA271117
B	see 1.1.	BPW	AGS-	2	max. 706 mm	BPW 6502	AA281117

3.2.2. Declared maximum brake input torque  $C_{max}$  ..... 2800 Nm  
 for calculation (pm= 650 kPa) ..... 2250 Nm  
 In case of camshaft with gearing A42x38 DIN 5482:  
 Declared maximum brake input torque  $C_{max}$  ..... 3700 Nm  
 for calculation (pm= 650 kPa) ..... 3000 Nm

3.2.3. Mechanical efficiency  $\eta =$  ..... 0,8

3.2.4. Declared brake input threshold torque  $C_{0,dec}$  ..... 50 Nm

3.2.5. Effective length of the cam shaft ..... see 3.2.1.6.



3.3. Brake drum

3.3.1.	3.3.2.	3.3.3.	3.3.4.	3.3.5.	3.3.6.
Max diameter of friction surface (wear limit)	Base material	Declared mass	Nominal mass	Brake drum	Identification Code
425,5 mm	cast iron	58 kg	50,6 kg	without hub	BPW 03.10x.xx.xx.x*

3.4. Brake lining

3.4.1 Brake lining data TMD Friction

3.4.1.1 Manufacturer and address ..... TMD Friction, Leverkusen

3.4.1.2 Make ..... Textar

3.4.1.3 Type ..... T 090

3.4.1.4 Identification (type identification on lining) .....Textar T 090

3.4.1.5 Minimum thickness (wear limit) ..... 5 mm

3.4.1.6 Method of attaching friction material to brake shoe ..... riveted

3.4.1.6.1 Worst case of attachment (in the case of more than one)..... not applicable

3.4.1.6.2 Range of the weight of one brake shoe (without linings and rollers)..... min. 6,2 kg

3.4.1.6.3 Base material of the brake shoes: ..... steel

\* The different numbers characterized in this information document with "x" are representing versions of the drum, whose modifications have however no influence on the function and effect regarding the tests carried out in accordance to ECE-Regulation No. 13 and are not part of the identification code.

3.4.1	Brake lining data Bremskerl	
3.4.1.1	Manufacturer and address .....	Bremskerl, Estorf-Leeseringen
3.4.1.2	Make .....	BPW
3.4.1.3	Type .....	6502
3.4.1.4	Identification (type identification on lining) .....	BPW 6502
3.4.1.5	Minimum thickness (wear limit) .....	5 mm
3.4.1.6	Method of attaching friction material to brake shoe .....	riveted
3.4.1.6.1	Worst case of attachment (in the case of more than one).....	not applicable
3.4.1.6.2	Range of the weight of one brake shoe (without linings and rollers).....	min. 6,2 kg
3.4.1.6.3	Base material of the brake shoes: .....	steel

