

Test Report

No. TDB 0568 dated 26.02.2003

for application of Annex 11, ECE Regulation No. 13

RWTÜV Fahrzeug GmbH

A RWTÜV Group Company

Institute for Vehicle Technology
Adlerstraße 7
D-45307 Essen
Telephone: +49(0)201825-0
Fax: +49(0)201825-4150

Corporate seat: Essen
Commercial Register section
B 9975
Chairman of the Supervisory
Board:
Elmar Legge

Management:
Prof. Dr. Claus Wolff (Vors.)
Friedo Schäfer

1 IDENTIFICATION

1.1 Axle

Manufacturer: BPW Bergische Achsen
Kommanditgesellschaft
D-51674 Wiehl

Make: BPW

Type: D -115

Model: -

Technically permissible axle load P_e ¹⁾: 11330,5 daN ($\hat{=}$ 11550 kg)

1.2 Brake

Manufacturer: See 1.1

Make: BPW

Type: SB 4345

Caliper: - Manufacturer: KNORR-BREMSE
- Type: SB 7 ...
- Variant: SN 7 ...

Note: The unspecified characters “...” in the KNORR-BREMSE part numbers specified above have no bearing on the function and effect with regard to the tests performed. (The unspecified characters “...” denote modifications and options like fitment or non fitment of wear sensors, kind of connection of the brake cylinder, mounting dimensioning of the brake for the vehicle axle, right / left version etc.)

The variant “SN7...” is added by KNORR-BREMSE to the original “SB7...” type designation and represents a version which has identical brake characteristics compared to the original one.

This has been verified by comparison tests.

- Method of construction: Floating caliper brake (pneumatic)

Brake lever: - Ratio l_e / e_e : 88 mm / 5,75 mm

Technically permissible camshaft
input torque $C_{max,e}$: 1550 Nm
(for calculation: 1260 Nm at 6,5 bar)

¹⁾ See sheet 4/4

Test Report No. : TDB 0568
Sheet : 2 / 4
Date : 26.02.2003



Manufacturer : BPW
Type of axle : D -115

Automatic brake adjustment device: Integrated

Brake disc: - Outside diameter: 430 mm
- Effective radius r_e : 171,5 mm
- Thickness: 45 mm
- Mass: 36 kg
- Material: Cast iron (grey cast iron)
- Method of construction: Internally ventilated brake disc

Brake pad: - Manufacturer: Honeywell Bremsbelag GmbH
- Make, - Type: JURID, JURID 539
- Identification: Type indication on brake-pad plate
- Width: 247,6 mm
- Thickness: 30 mm (incl. 9mm back plate)
- Surface area: 2x206 cm²
- Method of attachment: Friction material pressed on back plate

Schematic representation: See appendix 2 dated 26.02.2003

1.3 Wheel (Single/Twin)

Rim diameter D_e : 571,5 mm (22,5")
Dimensions: See appendix 1 dated 26.02.2003

1.4 Tyres

Dynamic rolling radius R_e
at reference load P_e : See appendix 1 dated 26.02.2003

1.5 Actuation

Brake actuator - Manufacturer: KNORR-BREMSE
- Type: Diaphragm brake actuator
- Model: 30" (BS 3658)

1.6 Automatic brake adjustment device: Not applicable (see 1.2)



Test Report No. : TDB 0568
 Sheet : 3 / 4
 Date : 26.02.2003



Manufacturer : BPW
 Type of axle : D -115

2 RECORD OF TEST RESULTS ²⁾

(corrected to take account of rolling resistance $\hat{=} 0,01 P_e$)

2.1 In the case of vehicles of categories O₂ and O₃

Test type:		0	I	
Annex 11, Appendix 2, point:		3.5.1.2	3.5.2.2/3	3.5.2.4
Test speed	km/h	40	40	40
Brake actuator pressure p _e	bar	5,4	-	5,4
Braking time	min	-	2,55	-
Brake force developed T _e	daN	7468	855	6429
Brake efficiency T _e / P _e	-	0,65	0,07	0,56
Actuator stroke s _e	mm	36	-	35
Camshaft input torque C _e	Nm	874	-	874
C _{0,e}	Nm	9	-	9

2.2 In the case of vehicles of category O₄

Test type:		0	III	
Annex 11, Appendix 2, point:		3.5.1.2	3.5.3.1.2	3.5.3.2
Test speed				
initial	km/h	60	60	60
final	km/h	0	30	0
Brake actuator pressure p _e	bar	5,4	-	5,4
Number of brake applications	-	-	20	-
Duration of braking cycle	s	-	60	-
Brake force developed T _e	daN	7588	3705	5957
Brake efficiency T _e / P _e	-	0,66	0,32	0,52
Actuator stroke s _e	mm	38	-	34
Camshaft input torque C _e	Nm	874	-	874
C _{0,e}	Nm	9	-	9

2.3 Performance of the automatic brake adjustment device

2.3.1 Free running according to paragraphs 3.6.1 and 3.6.3. of Annex 11,
 Appendix 2: yes

²⁾ See sheet 4/4



Test Report No. : TDB 0568
Sheet : 4 / 4
Date : 26.02.2003



Manufacturer : BPW
Type of axle : D -115

3 NAME OF TECHNICAL SERVICE CONDUCTING THE TEST

RWTÜV Fahrzeug GmbH
Technischer Dienst für Bremsanlagen
D-45307 Essen

4 DATE OF TEST: 26.03.1999

5 This test has been carried out and the result reported in accordance with ECE Regulation No. 13, supplement 6 to the 09 series of amendments, paragraph 4 and Annex 11, Appendix 2.

6 At the end of test defined in paragraph 3.6 of Annex 11, Appendix 2 the requirements of paragraph 5.2.2.8.1 of ECE Regulation No. 13 were deemed to be fulfilled.

Essen, 26.02.2003
B6-205 10 001-

Dipl.-Ing. Böker



LABORATORY FOR VEHICLE TECHNOLOGY
Testing Laboratory for Braking Systems
according to ECE Regulation No.13

7 TEST DOCUMENTS

/ Appendix 1: Dimensions brake drum / wheel / tyre (2 sheets)

/ Appendix 2: Schematic representation of brake (1 sheet)

¹⁾ Calculation with $g = 9,81 \text{ m/s}^2$

²⁾ Inertia dynamometer test, twin-wheel, $R_e = 526 \text{ mm}$,

Test Report No. : TDB 0568
 Appendix : 1
 Sheet : 1 / 2
 Date : 26.02.2003



Manufacturer : BPW
 Type of axle : D-115

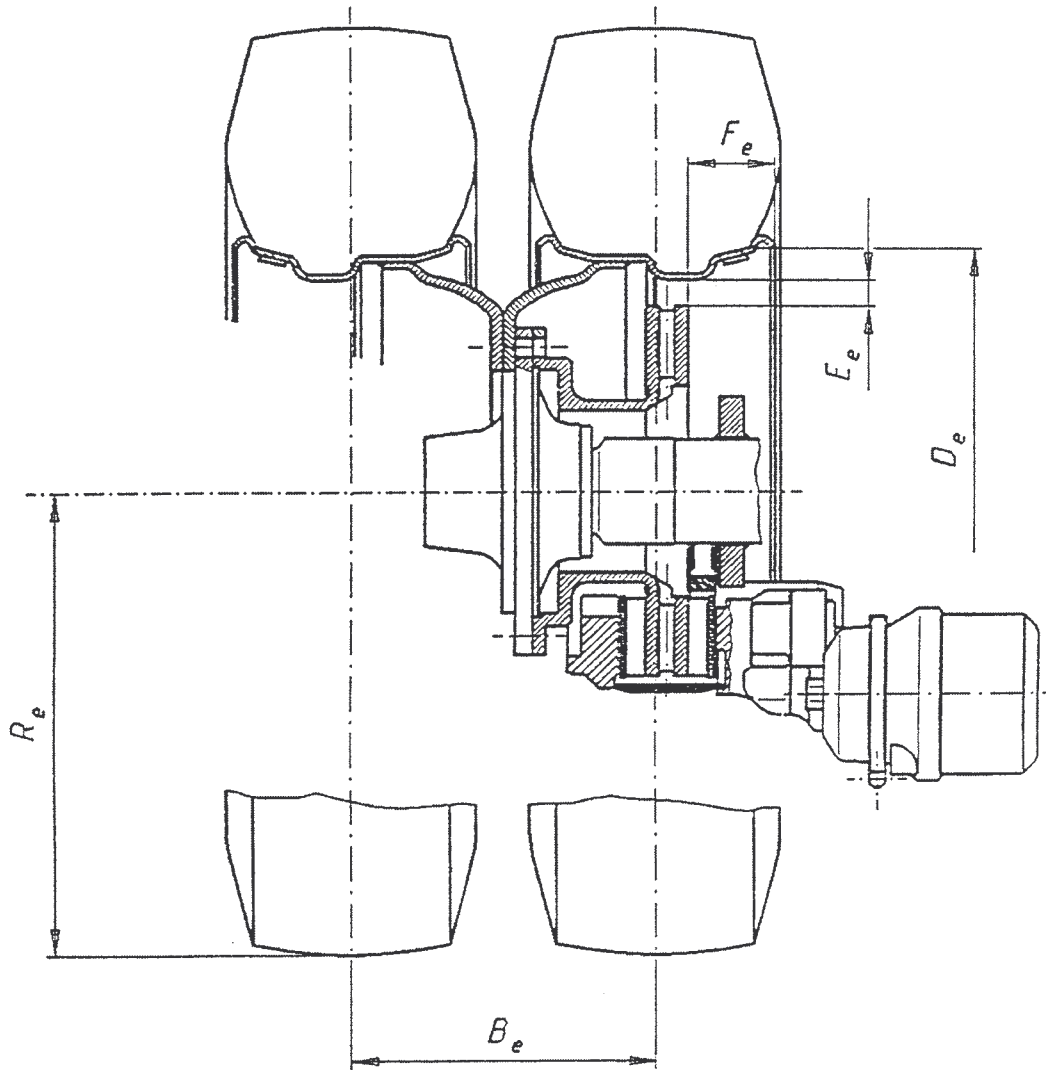

Brake disc		Axle load		Tyre	Rim	B_e	R_e	D_e (mm)	E_e	F_e
width X_e (mm)	mass (kg)	P_e (daN)	(kg)							
45	36	11330,5	11550	12 R 22,5	22,5 x 9,00	350	526	571,5	30	-124
45	36	11330,5	11550	13 R 22,5	22,5 x 9,00	350	546	571,5	30	-124



Test Report No. : TDB 0568
 Appendix : 1
 Sheet : 2 / 2
 Date : 26.02.2003



Manufacturer : BPW
 Type of axle : D -115

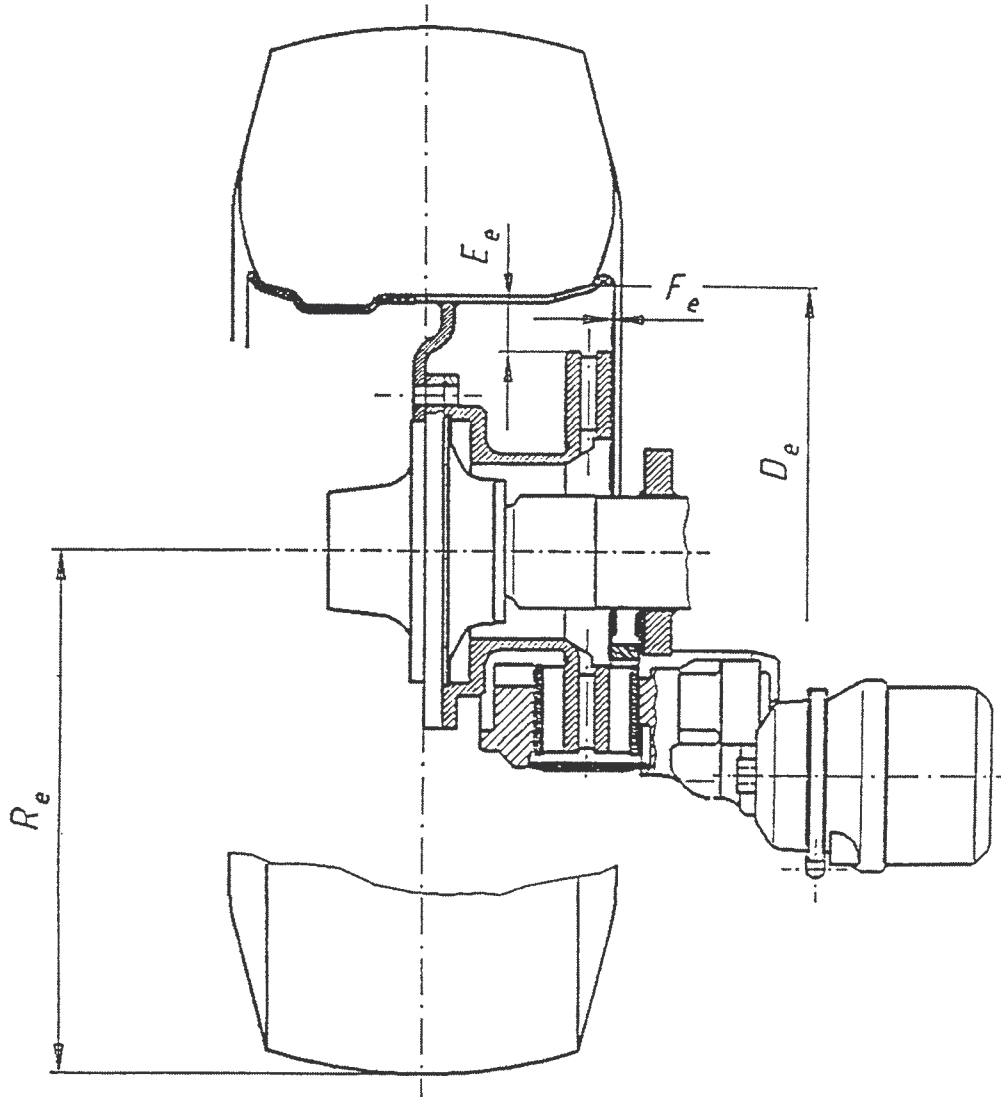

Brake disc		Axle load		Tyre	Rim	B _e	R _e	D _e	E _e	F _e
width X _e (mm)	mass (kg)	P _e (daN)	(kg)							
45	36	11330,5	11550	445/65 R 22,5	22,5 x 14,00	---	558	571,5	51	-24
45	36	11330,5	11550	385/65 R 22,5	22,5 x 12,25	---	519	571,5	51	-24

Test Report No. : TDB 0568
 Appendix : 2
 Sheet : 1 / 1
 Date : 26.02.2003



Manufacturer : BPW
 Type of axle : D -115

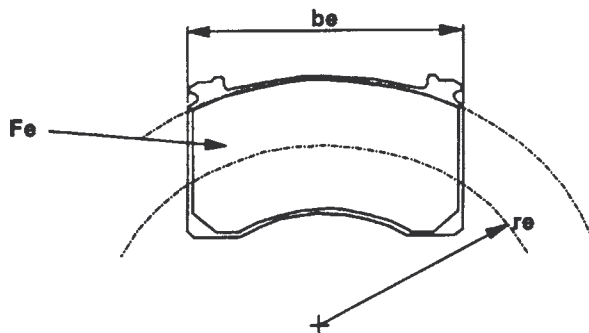
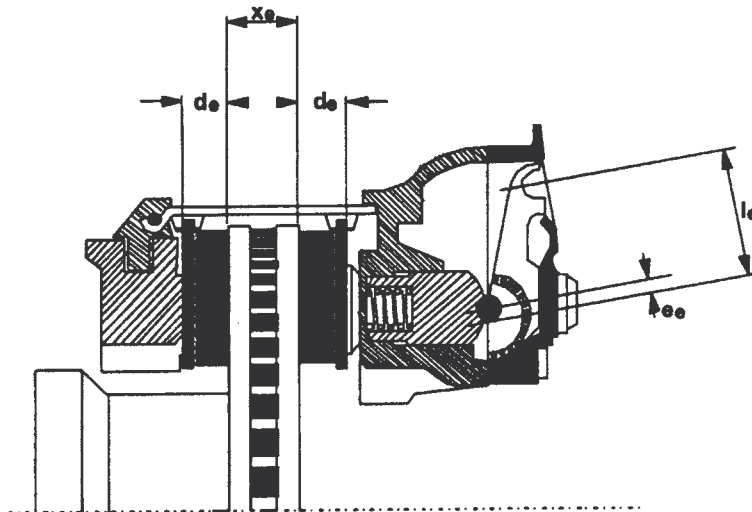

l_e (mm)	e_e (mm)	d_e (mm)	x_e (mm)	r_e (mm)	b_e (mm)	F_e (cm ²)
88	5,75	30	45	171,5	247,6	2x206

