

Wheel studs for single-tyre steel and aluminium wheels with zero offset (ET = 0).

As already reported in BPW Info aktuell IA-99/3, BPW has been supplying trailer axles with a new wheel stud version since 12/1998. These axles are for single-tyre steel and aluminium wheels. The introduction of this standard stud (BPW no.: 03.296.33.14.1) in conjunction with the BPW wheel nut means that one axle can now be used for both applications. The wheel stud is surface treated, giving it long-term protection against corrosion. It is allowed to be used for wheel naves with a thickness of up to 25.5 mm. Longer wheel studs must be used for wheels with thicker nave values. Alternatively, a wheel with a stud hole diameter of 32 mm can be used in conjunction with a shouldered nut.

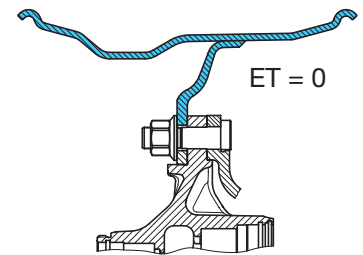

Old versions up to 11/1998

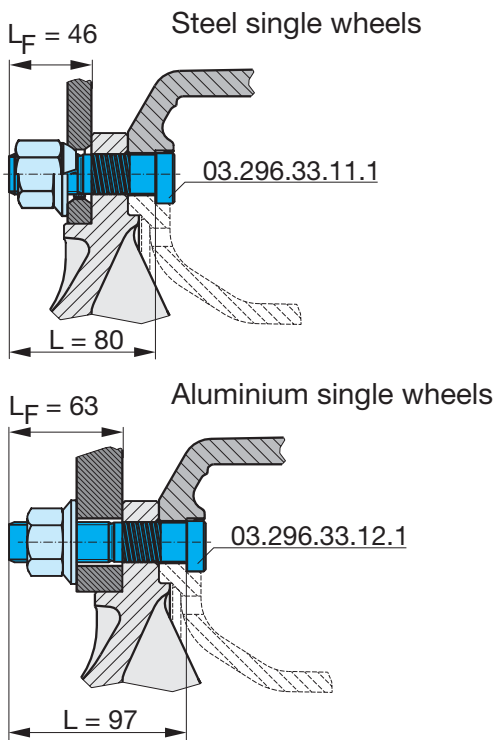

New version from 12/1998 with standard wheel stud

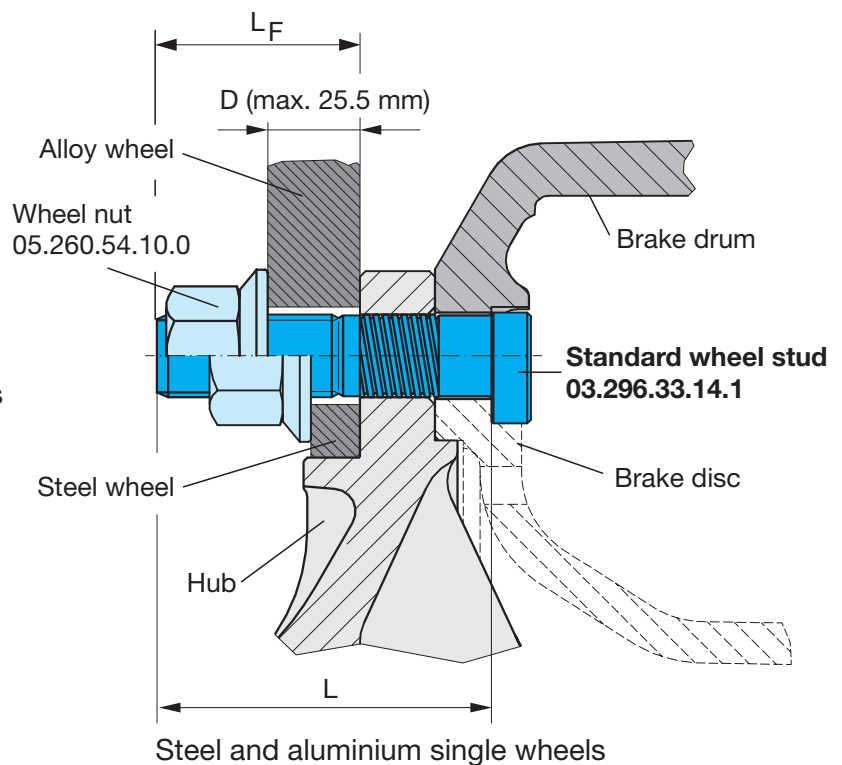

Wheel stud code number	Length L	Length L _F	Wheels for single tyres			
			Steel	Al Ø 26 mm, D ≤ 25.5 mm	Al Ø 26 mm, D > 25.5 mm	Al Ø 32 mm
03.296.33.14.1	89 mm	55 mm	✓	✓	---	with shouldered nut
03.296.33.12.1	97 mm	63 mm	---	---	✓	---