



The brands of the BPW Group:



NEWS Trailer

74151901e

14.02.2019

Series launch of the new ECO Air

From May 2019, the new BPW ECO Air air suspension will be introduced with the new disc brake ECO Disc TS2 and the well-known drum brake ECO Drum.

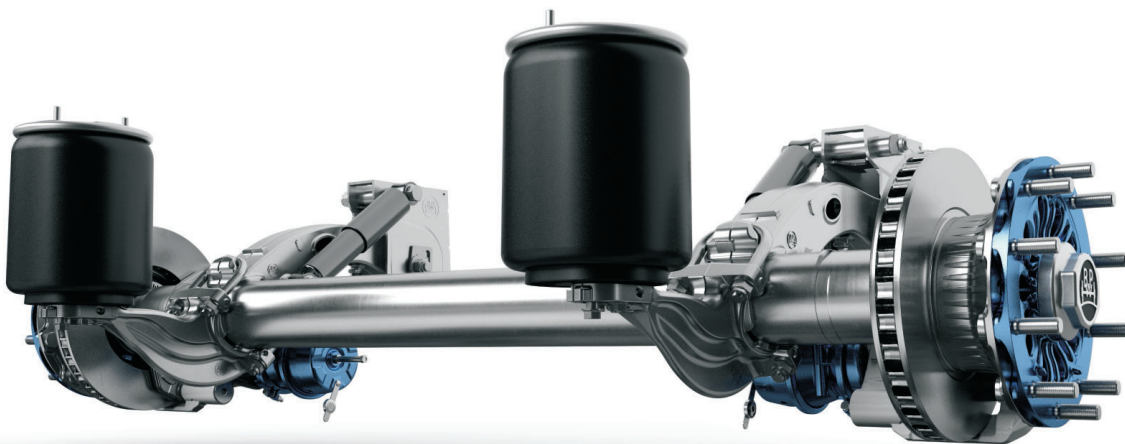

BPW ECO Air is the new running gear generation from BPW. It is lighter, more versatile, more efficient and digital and has been new designed from the ground up.

The two well-known versions „ECO Air Compact“ and „ECO Air Compact HD“ will be replaced by the new „ECO Air“.

The series launch with the new disc brake BPW ECO Disc TS2 and the well-known drum brake ECO Drum will take place from May 2019.

This results in the following timetable:

From February 2019:

BPW will provide conversion lists (old ECO Air Compact/ ECO Air Compact HD and correspondingly new ECO Air versions) to ensure a smooth conversion. These changeover lists will be sent to you within the next few days.

From March 2019:

New and already existing orders with ECO Air Compact/ ECO Air Compact HD with the order confirmation date from week 19/2019 on will be entered or transferred in the new ECO Air version after consultation with the customer.



From May 2019:

Over a period of 6 weeks, all customers will be converted step by step to 100% ECO Air. We will inform you about the exact conversion date in good time. You will also be informed about the conversion of your orders in the order confirmation.

After the conversion, delivery will only take place with the new air suspension ECO Air.

Note:

Further information about the series launch of the new BPW ECO Disc TS2 disc brake can be found in the following two BPW News

- BPW News 74091801e: Series launch of the new disc brake BPW ECO Disc TS2
- BPW News 74111801e: The second step: Series launch of the new disc brake BPW ECO Disc TS2

BPW has carried out corresponding sample reports for the new disc brake BPW ECO Disc TS2 for vehicle manufacturers with 9 different european testing organisations, which mean a significant simplification of vehicle homologation and type approval and therefore also a reduction of costs.

Further details can be found in the BPW News

- BPW News 73891713e: Sample reports for the homologation of the new trailer disc brake BPW ECO Disc TS2

or are available from your BPW contact person.

The sample reports have been available on the BPW website under „myBPW“ since the beginning of 2018.

The sample reports have now been updated and supplemented once again:

The reports from RDW and SGS TÜV Saar now include higher parking brake values for the TS2 4309 in the semi-trailer. Furthermore new certificates for the turntable or drawbar trailer with the RDW and the SGS TÜV Saar for the TS2 3709 and the TS2 4309 were carried out.