



The brands of the BPW Group:



NEWS Aftermarket



74191901e

AM01 / 2019

Conversion of brake shoes and return springs for BPW stub axle MVBFST 10010 and BPW steering axle stub MVBFLST with brake SN 4218

As of March 2019, certain BPW stub axles and BPW steering axle stubs will be provided with modified brake shoes and return springs, which react less sensitively to vibrations in the vehicle and on the axle.

To enable existing versions to also use the modified brake shoes and return springs for repairs, the previous components will be eliminated and replaced by repair kit 09.801.08.84.0.

Brake shoe assembly old: 05.091.46.32.1

replaced by

Brake shoe assembly new: 05.091.46.41.1

Return spring old: 03.397.34.20.0

replaced by

Return spring new: 05.397.34.22.0

Return spring old: 03.397.46.14.0

replaced by

Return spring new: 05.397.46.15.0

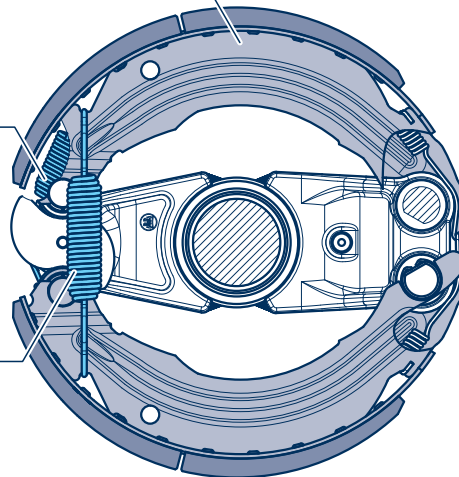

The brake shoes and return springs are to be eliminated only in defined BPW stub axles with B-hub, spare part 45, and a brake drum in front of the wheel hub. The series brake SN 4218 in 9t axles remains unchanged.

Repair kit **09.801.08.84.0** for the defined BPW stub axle or steering axle stub comprises:

4 x Brake shoe assembly	05.091.46.41.0
2 x Return spring	05.397.34.22.0
2 x Return spring	05.397.46.15.0

