



Launch of the BPW center axle landing leg in October 2016!

The product portfolio of BPW landing legs is expanded with 2 types of landing legs for center axle trailers.

Advantages at a glance

- › Lightweight: depending on type 39 - 50 kg
- › Robust design: strengthened shaft
- › Modern design: partly integrated gearing
- › Optimised sealing: cover of the gearing with peripheral sealing, suitable for high pressure cleaner
- › Low crank forces for easy operation
- › Continuous screw-on plate for flexible installation
- › Maintenance-free for 3 years e.g. due to long-term lubrication of the spindle with ECO Li 91
- › High-quality powder coating for protection against corrosion

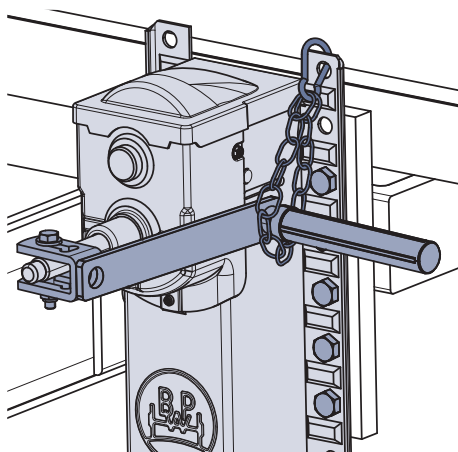
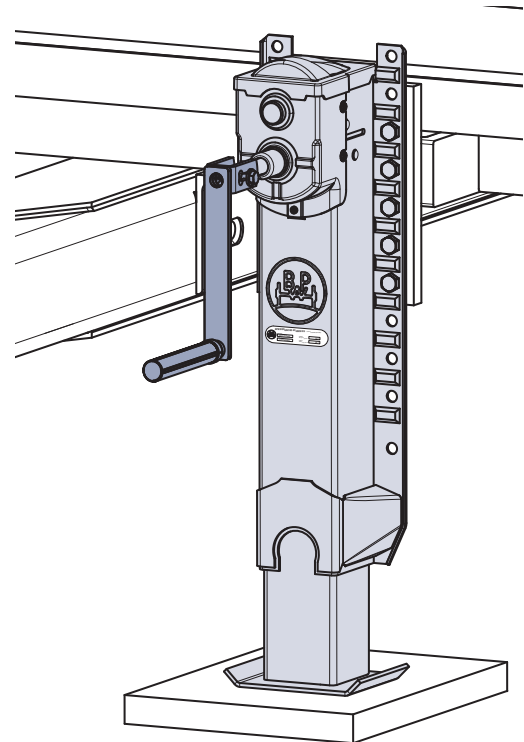

Type 1

- available in 4 different length: 570 - 715 mm
- spindle stroke depending on length: 325 - 470 mm

Type 2

- length 760 mm with 410 mm spindle stroke and extra drop lift of 400 mm